



Heating and Air Conditioning

TECHNICAL GUIDE (R-407C)

SINGLE PACKAGE GAS/ELECTRIC UNITS AND SINGLE PACKAGE AIR CONDITIONERS

DC 036, 048, 060 & 076

3, 4, 5 & 6.3 NOMINAL TONS

(50 HZ EXPORT)

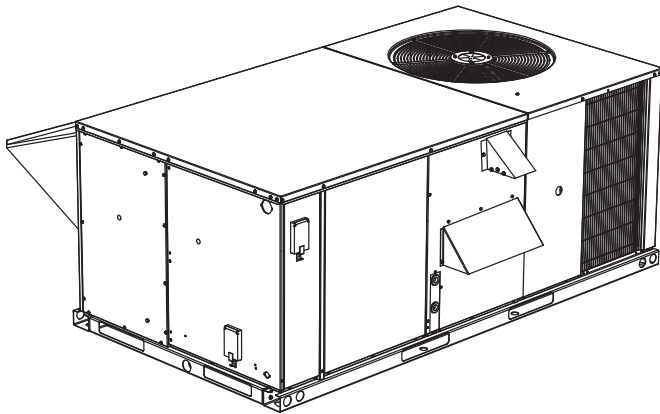

DESCRIPTION

YORK Sunline 2000™ units are convertible single package air conditioners with a common cabinet and a common roof curb for the 3, 4, 5 and 6.3 ton sizes. The units were designed for light commercial and commercial applications. They can easily be installed on a roof curb, slab, roof jack or frame.

All units include:

- Powder Paint finish that meets ASTM-B-117 1000 hour salt spray standards
- Permanently lubricated motors
- Bottom or side air discharge configuration capability (field convertible)
- Manufactured under the quality standards of ISO9001
- **Simplicity**® Control Board
- Copper tube/aluminum fin coils
- Easy access to all components
- Rigging holes in base rails for lifting
- Fork lift slots on three sides
- Single point power connection
- Complete factory package - tested, charged and wired

TABLE OF CONTENTS

DESCRIPTION	1
PRODUCT NOMENCLATURE	3
FEATURES	4
FACTORY-INSTALLED OPTIONS	7
FIELD-INSTALLED ACCESSORIES	7

LIST OF FIGURES

<u>Fig. #</u>	<u>Pg. #</u>
1 UNIT CUTAWAY	6
2 TYPICAL FIELD POWER & CONTROL WIRING	20
3 UNIT DIMENSIONS (3 - 6 TON COOLING ONLY/ ELECTRIC HEAT) FRONT VIEW	21
4 UNIT DIMENSIONS (3 - 6 TON COOLING/GAS HEAT) FRONT VIEW	21
5 UNIT WITH ECONOMIZER RAINHOOD	22
6 UNIT WITH FIXED OUTDOOR AIR/MOTORIZED DAMPER RAINHOOD	22
7 UNIT DIMENSIONS (REAR VIEW)	23
8 DISCONNECT/BLOWER ACCESS LOCATION	23
9 TYPICAL APPLICATIONS	24
10 FOUR AND SIX POINT LOADING	25
11 ROOF CURB DIMENSIONS	26

LIST OF TABLES

<u>Tbl. #</u>		<u>Pg. #</u>
1	SOUND POWER RATING	9
2	CAPACITY RATINGS - (ARI 210/240)	9
3	GAS HEAT RATINGS	9
4	DC036 COOLING CAPACITIES (3 TON)	10
5	DC048 COOLING CAPACITIES (4 TON)	11
6	DC060 COOLING CAPACITIES (5 TON)	12
7	DC076 COOLING CAPACITIES (6.3 TON)	13
8	SUPPLY AIR BLOWER PERFORMANCE (3 & 4 TON DIRECT DRIVE) - SIDE DUCT APPLICATION	14
9	SUPPLY AIR BLOWER PERFORMANCE (5 TON BELT DRIVE) - SIDE DUCT APPLICATION	15
10	SUPPLY AIR BLOWER PERFORMANCE (6.3 TON BELT DRIVE) - SIDE DUCT APPLICATION	16
11	BELT DRIVE MOTOR AND DRIVE DATA	17
12	STATIC RESISTANCES	17
13	ELECTRIC HEATER SUPPLY AIR LIMITATIONS ..	17
14	ELECTRICAL DATA: 3 - 6.3 TON	18
15	PHYSICAL DATA	19
16	ELECTRIC HEAT CORRECTION FACTORS	19
17	VOLTAGE LIMITATIONS	19
18	UTILITIES ENTRY	23
19	MINIMUM CLEARANCES	23
20	DC 4 POINT LOADS WEIGHT DISTRIBUTION (KG / LBS)	25
21	DC 6 POINT LOADS WEIGHT DISTRIBUTION (KG / LBS)	25
22	CENTER OF GRAVITY	25
23	OPERATING WEIGHTS (KG / LBS.)	26

PRODUCT NOMENCLATURE

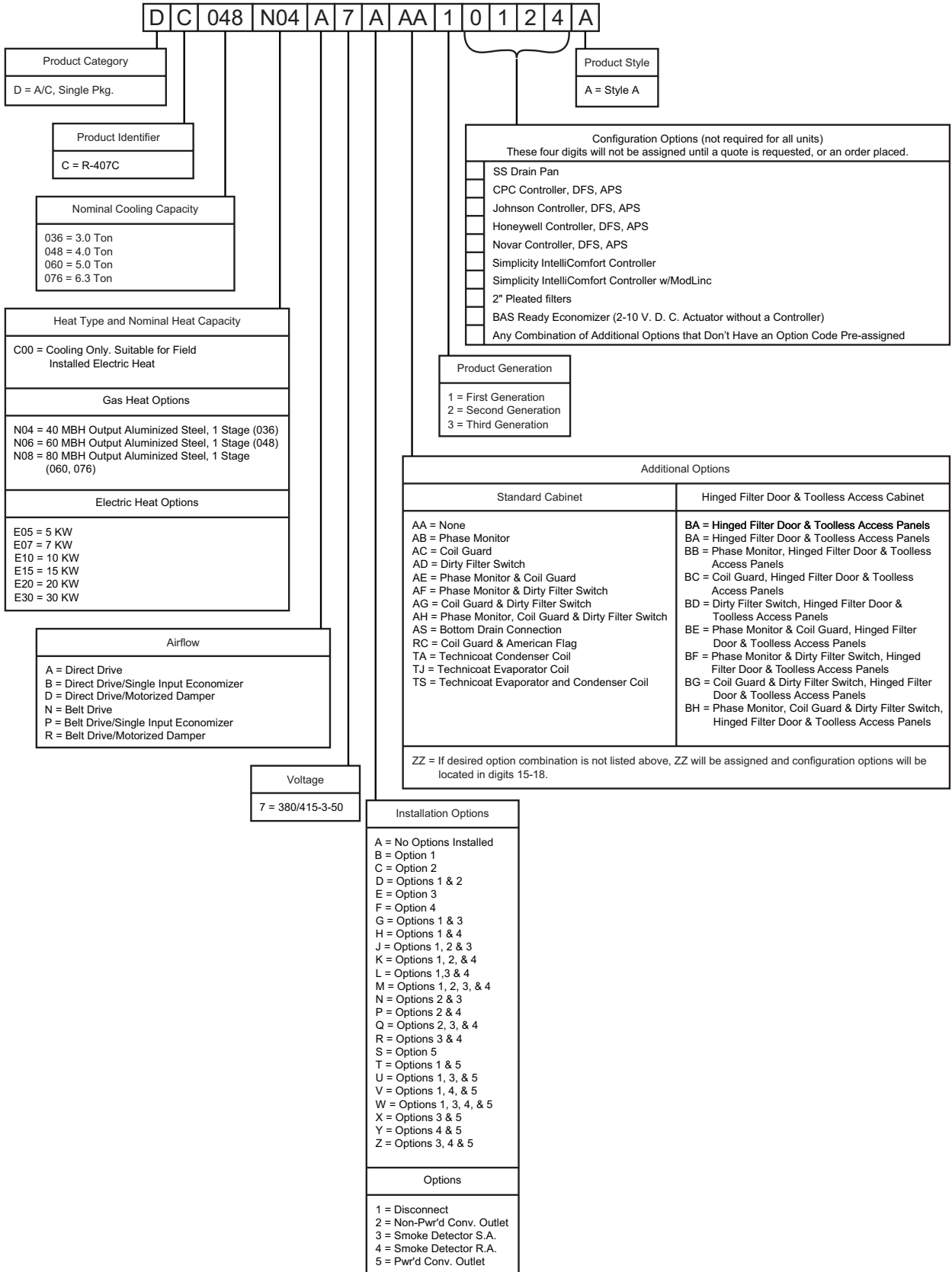

FEATURES

All models are available with a wide variety of factory-mounted options such as stainless steel heat exchangers, phase monitor, dirty filter switch, and coil guard to make them suitable for almost every application.

All units are self-contained and assembled on full perimeter base rails with forklift holes on three sides and holes for overhead rigging. Every unit is completely piped, wired, charged and tested at the factory to simplify the field installation and to provide years of dependable operation.

All models (including those with an economizer) are suitable for either bottom or horizontal duct connections. For bottom duct, remove the sheet metal panels from the supply and return air openings through the base of the unit. For horizontal duct, remove the supply and return air panels on the rear of the unit.

All models are available with these “factory mounted” outdoor air damper options:

- Single enthalpy economizer
- Motorized outdoor air damper

Supply air blowers are equipped with either a direct drive or a belt drive that can be adjusted to meet the exact requirements of the job.

All compressors are equipped with internal pressure relief. Every refrigerant circuit includes a liquid line filter-drier, a high pressure switch and a suction line with a freezestat and low pressure/loss of charge switch to protect all system components.

- **Simplicity® Controls** - **Simplicity®** control boards have standardized a number of features previously available only as options or by utilizing additional controls.
 - **Low Ambient** - An integrated low-ambient control allows all units to operate in the cooling mode down to 0°F outdoor ambient without additional assistance. Optionally, the control board can be programmed to lockout the compressors when the outdoor air temperature is low or when free cooling is available.

CAUTION

The Simplicity® control board used in this product will effectively operate the cooling system down to 0°F when this product is applied in a comfort cooling application for people. An economizer is typically included in this type of application. When applying this product for process cooling applications (computer rooms, switchgear, etc.), please reference applications bulletin AE-011-07 or call the applications department for Unitary Products @ 1-877-UPG-SERV for guidance. Additional accessories may be needed for stable operation at temperatures below 30° F.

- **Anti-Short Cycle Protection** - To aid compressor life, an anti-short cycle delay is incorporated into the standard controls. Compressor reliability is further ensured by programmable minimum run times. For testing, the anti short cycle delay can be temporarily overridden with the push of a button.
- **Fan Delays** - Fan on and fan off delays are fully programmable and are independent of one another. All units are programmed with default values based upon their configuration of cooling and heat.
- **Safety Monitoring** - The control board monitors the high and low-pressure switches, the freezestats, the gas valve, if applicable, and the temperature limit switch on gas heat units. The unit control board will alarm on ignition failures, compressor lockouts and repeated limit switch trips.
- **Nuisance Trip Protection**- To prevent nuisance trouble calls, the control board uses a “three strikes, you’re out” philosophy. The high and low-pressure switches and the freezestats must trip three times within two hours before the unit control board will lock out the compressor.
- **On Board Diagnostics** - Each alarm will energize a trouble light on the thermostat, if so equipped, and flash an alarm code on the control board LED. Each high and low-pressure switch alarm as well as each freezestat alarm has its own flash code. The control board saves the five most recent alarms in memory, and these alarms can be reviewed at any time. Alarms and programmed values are retained through the loss of power.

All units have long lasting powder paint cabinets with 1000 hour salt spray test approval under ASTM-B117 procedures.

- **Gas Heat Operation** - All gas heat units have a minimum AFUE of 80%. Each section includes a durable heat exchanger with aluminized steel or optional stainless steel tubes, a redundant gas valve, spark ignition, power venting, an ignition module for 100% shut-off and all of the safety controls required to meet the latest ANSI standards.

The gas supply piping can be routed into the heating compartment through a hole in the base pan of the unit or through a knockout in the piping panel on the front of the unit.

- **Electric Heat Operation** - All electric heat models are wired for a single power source and include a bank of nickel chromium elements mounted at the discharge of the supply air blower to provide a high velocity and uniform distribution of air across the heating elements. Every element is fully protected against excessive temperature by thermal limit switches.

The power supply wiring can be routed into the control box through a threaded pipe connection (field supplied) in the base pan of the unit or through a knockout in the wiring panel on the side of the unit.

- **BAS Controls** - York's Sunline™ series units offer factory mounted BAS controls such as Novar, Honeywell, Johnson, and CPC.

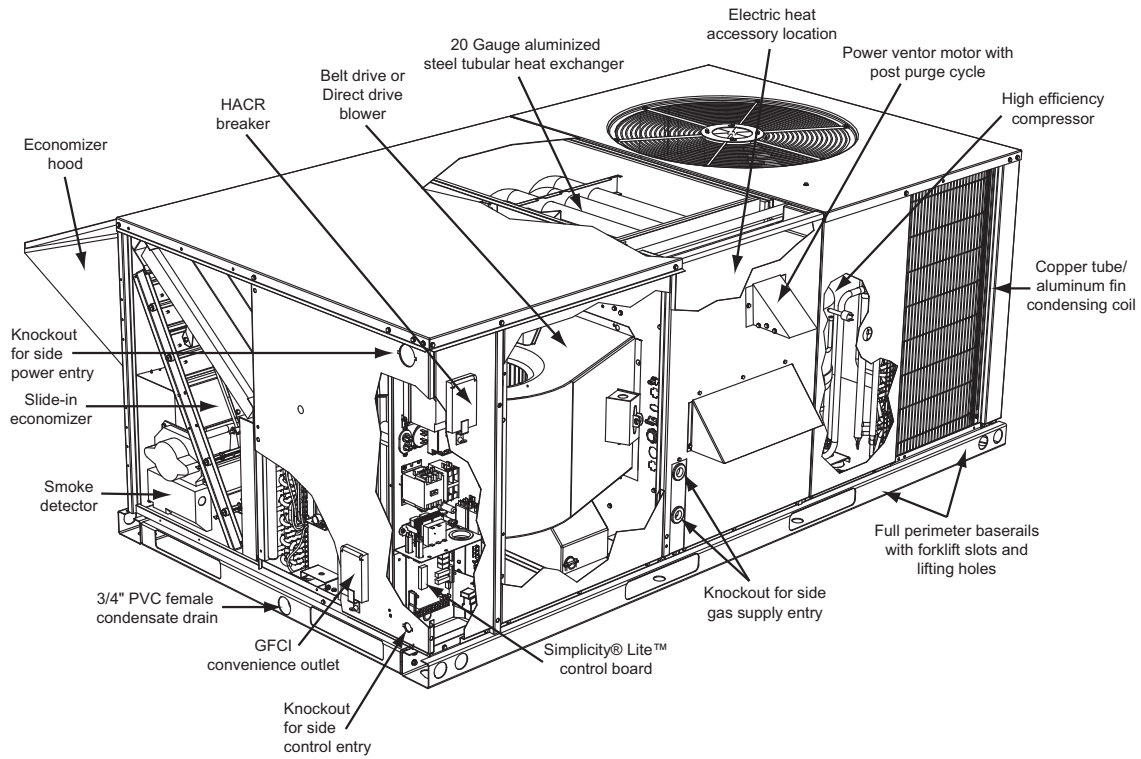

GAS/ELECTRIC

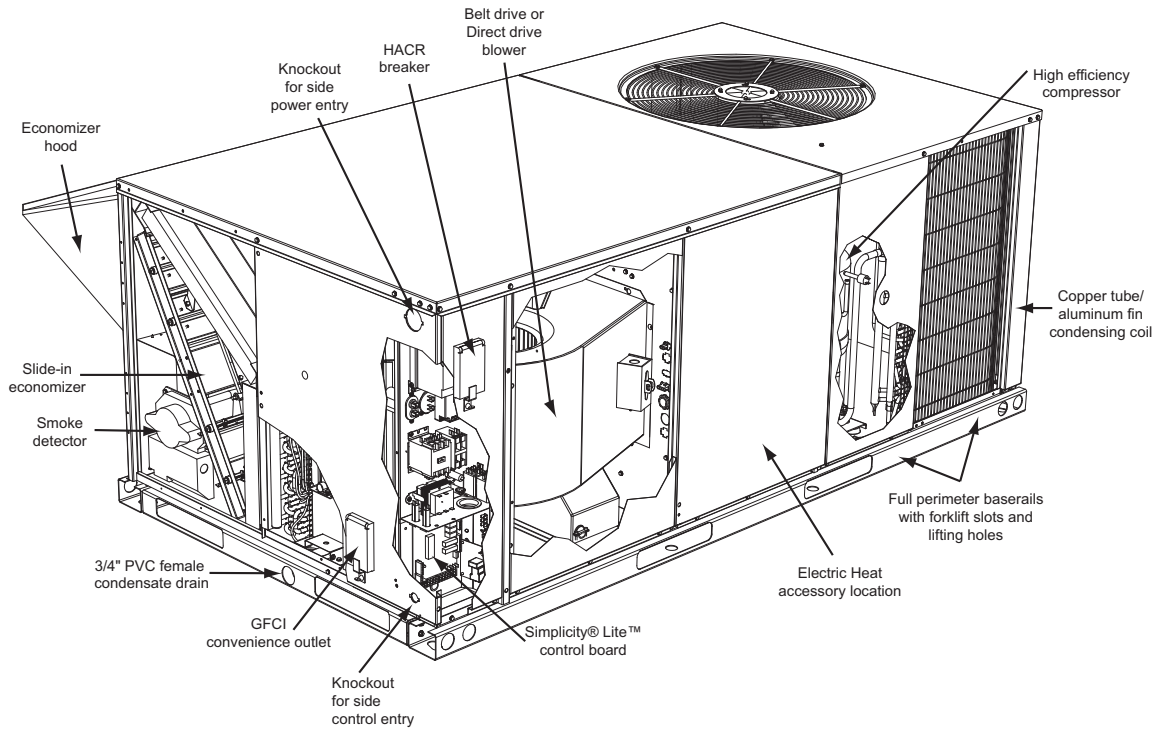

ELECTRIC/ELECTRIC
FIGURE 1 - UNIT CUTAWAY

FACTORY-INSTALLED OPTIONS

- **SINGLE INPUT ELECTRONIC ENTHALPY ECONOMIZERS** - Includes a slide-in / plug-in damper assembly with fully modulating spring-return motor actuator capable of introducing up to 100% outdoor air with nominal 1% leakage type dampers.

The enthalpy system contains one sensor that monitors the outdoor air and determines when the air is cool enough and dry enough to provide free cooling.

The rainhood is painted to match the basic unit and must be field-assembled before installing.

- **MOTORIZED OUTDOOR AIR INTAKE DAMPER** - Includes a slide-in / plug-in damper assembly with a 2-position, spring return motor actuator which opens to a pre-set position whenever the supply air blower is operating and will drive fully closed when the blower unit shuts down.

The rain hood is painted to match the basic unit and must be field assembled before installing.

- **PHENOLIC COATED EVAPORATOR AND CONDENSER COILS** - Special coating process that utilizes Technicoat 10-1™ processes. Coating is applied by total immersion of the complete coil for maximum protection.

- **ELECTRIC HEATERS** wired for single point power supply. These nickel chromium heater elements are provided with limit and automatic reset capability to prevent operation at excessive temperatures.

- **FILTER OPTIONS** - Standard units are shipped with 25mm (1") throw-away filters installed. 50mm (2") pleated filters are offered as a factory installed option.

- **CONVENIENCE OUTLET** - The unit may be ordered with a "non-powered" convenience outlet that can be wired in the field.

- **DISCONNECT SWITCH** - For gas heat units and cooling units with electric heat, a HACR breaker sized to the unit is provided. For cooling only units, a switch sized to the largest electric heat available for the particular unit is provided. Factory installed option only.

- **BAS** - See "Additional Options" section in the product nomenclature.

- **SMOKE DETECTORS** - (supply air & return air) The smoke detectors stop operation of the unit by interrupting power to the control board if smoke is detected within the air compartment.

- **COIL GUARD** - Customers can purchase a coil guard kit to protect the condenser coil from damage. This is not a hail guard kit.
- **STAINLESS STEEL HEAT EXCHANGER** - For applications in corrosive environments, this option provides a full stainless steel heat exchanger assembly.
- **PHASE MONITORS** - Designed to prevent unit damage. The phase monitor will shut the unit down in an out-of-phase condition.
- **DIRTY FILTER SWITCH** - This kit includes a differential pressure switch that energizes the fault light on the unit thermostat, indicating that there is an abnormally high pressure drop across the filters. Factory installed option or field installed accessory.
- **HINGED FILTER DOOR/"TOOLLESS" BLOWER AND ACCESS PANELS** (not hinged) - This option allows for easy access and maintenance.

NOTE: Knobs are shipped inside the unit to prevent shipping damage. These must be field installed for tool-less operation.

FIELD-INSTALLED ACCESSORIES

- **SINGLE INPUT ELECTRONIC ENTHALPY ECONOMIZERS** - Includes a slide-in / plug-in damper assembly with fully modulating spring-return motor actuator capable of introducing up to 100% outdoor air with nominal 1% leakage type dampers.

The enthalpy system contains one sensor that monitors the outdoor air and determines when the air is cool enough and dry enough to provide free cooling.

The rainhood is painted to match the basic unit and must be field-assembled before installing.

- **MOTORIZED OUTDOOR AIR INTAKE DAMPER** - Includes a slide-in / plug-in damper assembly with a 2-position, spring return motor actuator which opens to some pre-set position whenever the supply air blower is operating and will drive fully closed when the blower unit shuts down.

The rain hood is painted to match the basic unit and must be field assembled before installing.

- **ELECTRIC HEATERS** wired for single point power supply. These nickel chromium heater elements are provided with limit and automatic reset capability to prevent operation at excessive temperatures.

- **ROOF CURBS** - Eight and fourteen-inch high roof curbs provide a water-tight seal between the unit and the finished roof. These full perimeter curbs meet the requirements of the National Roofing Contractors Association (NRCA) and are shipped knocked-down for field assembly.

Roof curbs are designed to fit inside the base rails of the unit and include both a wood nailing strip and duct hanger supports.

 WARNING
Factory installed Smoke Detectors in the Return Air, may be subjected to freezing temperatures during "off" times due to Out Side Air infiltration. These Smoke Detectors have an operational limit of 32°F to 131°F. Smoke Detectors installed in areas that could be out side those limitations will have to be moved to prevent having false alarms.

- **HIGH ALTITUDE NATURAL GAS** - Burner orifices and pilot orifices are provided for proper furnace operation at altitudes up to 6,000 feet.
- **PROPANE** - Burner orifices, pilot orifices and gas valve parts are provided to convert a natural gas furnace to propane.
- **HIGH ALTITUDE PROPANE** - Burner orifices and pilot orifices are provided for proper furnace operation at altitudes up to 6,000 feet. This accessory supplements the basic propane conversion kit.
- **POWER EXHAUST** - Our single input economizer options are available with power exhaust. Whenever the outdoor air intake dampers are opened for free cooling, the exhaust fan will be energized to prevent the conditioned space from being over-pressurized during economizer operation.
The power exhaust option can only be used on bottom duct configurations.
- **BAROMETRIC RELIEF DAMPER** - This damper accessory can be used to relieve internal building air pressure on units with an economizer without power exhaust. This accessory includes a rain hood, a bird screen and a fully assembled damper. With bottom duct connections, the

damper should be mounted over the opening in the return air panel. With horizontal ductwork, the accessory should be mounted on the return air duct.

- **ENTHALPY ACCESSORY CONTROL KIT** - This kit contains the required components to convert a single enthalpy economizer to dual enthalpy.
- **BURGLAR BARS** - Mount in the supply and return openings to prevent entry into the duct work.
- **FLUE EXHAUST EXTENSION KIT** - In locations with wind or weather conditions which may interfere with proper exhausting of furnace combustion products, this kit can be installed to prevent the flue exhaust from entering nearby fresh air intakes.
- **CO₂ SENSOR** - Senses CO₂ levels and automatically overrides the economizer when levels rise above the present limits.
- **COIL GUARD** - Customers can purchase a coil guard kit to protect the condenser coil from damage. This is not a hail guard kit.
- **PHASE MONITORS** - Designed to prevent unit damage. The phase monitor will shut the unit down in an out-of-phase condition.

TABLE 1: SOUND POWER RATING¹

UNIT SIZE	CFM	ESP	BLOWER		SOUND POWER (db 10 ⁻¹² Watts)									
					Octave Band Centerline Frequency (Hz)								SWL dB(A)	dB(A) @ 10Ft. ²
					IWG	SPEED	KW	63	125	250	500	1,000		
036	1,200	0.6	LOW	0.60	84	84	74	67	69	62	57	52	74	41
048	1,600	0.55	HIGH	0.80	85	85	75	68	70	63	58	53	75	42
060	2,000	0.45	HIGH	1.00	86	86	76	69	71	64	59	54	76	43
076	2,200	0.3	HIGH	1.35	87	87	77	70	72	65	60	55	77	44

1. These values have been accessed using a model of sound propagation from a point source into the hemispheric/free field. The dBA values provided are to be used for reference only. Calculation of dBA values cover matters of system design and the fan manufacture has no way of knowing the details of each system. This constitutes and expectation to any specification or guarantee requiring a dBA value or sound data in any other form than sound power level ratings.
2. At a distance of 10 feet from the blower.

TABLE 2: CAPACITY RATINGS - (ARI 210/240)

UNIT SIZE	Cooling Capacity (80/67-95°F)/(27/19-35°C) Mbh/kW	Total Input kW	COP ¹	EER ²	ELECTRIC HEAT ³ NOMINAL CAPACITY kW
036	35.5 / 10.4	4.0	2.6	9.0	5.1, 7.5, 10.2, 14.6
048	45.1 / 13.2	5.1	2.6	8.9	5.1, 7.5, 10.2, 14.6
060	61.1 / 17.9	6.9	2.6	8.9	5.1, 7.5, 10.2, 14.6, 21.5
076	69.6 / 20.4	8.7	2.4	8.1	5.1, 7.5, 10.2, 14.6, 21.5

1. COP = Coefficient of Performance - total output kW divided by the total input kW.
2. EER = Energy Efficiency Ratio - total output Mbh divided by the total input kW.
3. Heaters available as factory-installed options or field-installed accessories - all with single point power supply.

TABLE 3: GAS HEAT RATINGS

GAS HEAT OPTION	INPUT CAPACITY kW{MBH}	OUTPUT CAPACITY kW{MBH}	AVAILABLE ON MODELS	GAS RATE ¹ M ³ /S{Ft ³ /Hr}	TEMPERATURE RISE °C{°F} AT FULL INPUT ²	
					MIN.	MAX
N04	15{50}	12{40}	3 TON	0.02{47}	8{15}	25{45}
N06	22{75}	18{60}	4 TON	0.03{70}	14{25}	21{70}
N08	29{100}	23{79}	5/6 TON	0.04{93}	14{25}	31{55}

1. Based on 1075 Btu/Ft³.
 2. The air flow must be adjusted to obtain a temperature rise within the range shown.
- NOTE: Gas Heaters are shipped available for natural gas, but can be covered to L.P. with Kit Model No. 1NP0434. All furnaces meet the latest California seasonal efficiency requirements.

TABLE 4: DC036 COOLING CAPACITIES (3 TON)

M ³ /S																															
Air On Evap.		Temperature of Air on Condenser Coil																													
M ³ /S	WB (°C)	35°C							41°C							46°C							52°C								
		Total Cap. ¹ (kW)	Tot. Input ² (kW)	Sensible Capacity				Total Cap. ¹ (kW)	Tot. Input ² (kW)	Sensible Capacity				Total Cap. ¹ (kW)	Tot. Input ² (kW)	Sensible Capacity				Total Cap. ¹ (kW)	Tot. Input ² (kW)	Sensible Capacity									
				Return Dry Bulb (°C)						Return Dry Bulb (°C)						Return Dry Bulb (°C)						Return Dry Bulb (°C)									
				31	28	25	22					31	28	25	22					31	28	25	22					31	28	25	22
0.70	23	12.1	3.6	9.0	6.1	3.4	-	10.7	3.9	8.2	5.7	3.0	-	9.3	4.1	7.5	5.2	2.7	-	7.7	4.2	6.5	4.3	2.3	-						
	20	11.4	3.5	11.4	8.7	5.9	3.2	10.2	3.8	10.1	8.1	5.3	2.8	8.9	4.0	8.9	7.4	4.7	2.4	7.2	4.1	7.2	6.3	4.1	2.0						
	17	11.4	3.5	11.4	10.6	8.4	5.6	10.2	3.8	10.1	9.1	7.6	5.0	8.9	4.0	8.9	8.5	6.9	4.4	7.2	4.1	7.2	7.0	6.0	3.8						
	14	11.4	3.5	11.4	10.6	9.8	8.1	10.2	3.8	10.1	9.1	8.7	7.4	8.8	4.0	8.8	8.5	7.6	6.6	7.2	4.1	7.2	6.9	6.4	5.8						
0.55	23	11.7	3.5	7.8	5.4	3.3	-	10.5	3.8	7.1	5.0	2.9	-	9.0	3.9	6.4	4.5	2.5	-	7.4	4.0	5.6	3.8	2.2	-						
	20	10.9	3.4	10.0	7.6	5.3	3.1	9.7	3.6	9.2	7.0	4.7	2.7	8.5	3.8	8.4	6.5	4.2	2.3	7.1	3.9	6.9	5.4	3.7	1.9						
	17	10.7	3.4	10.7	9.8	8.0	5.1	9.6	3.7	9.5	8.8	7.3	4.6	8.3	3.9	8.3	7.8	6.5	4.0	6.9	4.0	6.9	6.5	5.7	3.5						
	14	10.7	3.4	10.7	10.0	9.3	7.2	9.6	3.7	9.5	9.0	8.2	6.5	8.3	3.9	8.3	8.0	7.1	5.8	6.9	4.0	6.9	6.6	6.0	5.0						
0.45	23	11.2	3.5	6.4	4.7	3.1	-	10.0	3.8	5.8	4.3	2.7	-	8.6	3.9	5.2	3.9	2.4	-	7.1	4.0	4.6	3.2	2.0	-						
	20	10.3	3.4	8.2	6.4	4.6	3.0	9.2	3.7	7.5	5.9	4.1	2.6	7.9	3.8	6.7	5.4	3.7	2.3	6.5	3.9	5.9	4.5	3.1	1.9						
	17	9.7	3.3	9.7	8.1	6.3	4.5	8.7	3.5	8.6	7.5	5.6	4.0	7.5	3.6	7.5	6.9	5.0	3.5	6.2	3.8	6.2	5.7	4.4	3.0						
	14	9.7	3.3	9.7	9.0	8.0	6.1	8.7	3.6	8.6	8.2	7.3	5.6	7.5	3.7	7.5	7.2	6.4	4.9	6.2	3.8	6.2	5.9	5.5	4.2						

CFM																																
Air On Evap.		Temperature of Air on Condenser Coil																														
CFM	WB (°F)	95°F								105°F								115°F								125°F						
		Total Cap. ¹ (MBH)	Tot. Input ² (kW)	Sensible Capacity				Total Cap. ¹ (MBH)	Tot. Input ² (kW)	Sensible Capacity				Total Cap. ¹ (MBH)	Tot. Input ² (kW)	Sensible Capacity				Total Cap. ¹ (MBH)	Tot. Input ² (kW)	Sensible Capacity										
				Return Dry Bulb (°F)						Return Dry Bulb (°F)						Return Dry Bulb (°F)						Return Dry Bulb (°F)										
				86	80	74	68					86	80	74	68					86	80	74	68					86	80	74	68	
1500	72	41.1	3.6	30.7	21.0	11.6	-	36.6	3.9	28.0	19.4	10.4	-	31.6	4.1	25.4	17.6	9.1	-	26.3	4.2	22.3	14.7	7.7	-							
	67	38.9	3.5	38.9	29.8	20.0	10.8	35.0	3.8	34.5	27.6	18.1	9.6	30.2	4.0	30.2	25.3	16.1	8.2	24.6	4.1	24.6	21.4	13.9	6.8							
	62	38.9	3.5	38.9	36.2	28.8	19.0	34.9	3.8	34.5	31.0	26.0	17.1	30.2	4.0	30.2	29.0	23.5	15.1	24.7	4.1	24.7	23.7	20.5	13.1							
	57	38.8	3.5	38.8	36.2	33.6	27.7	34.8	3.8	34.4	31.0	29.6	25.2	30.2	4.0	30.2	29.0	25.8	22.6	24.6	4.1	24.6	23.7	21.7	19.7							
1200	72	40.1	3.5	26.5	18.5	11.2	-	35.7	3.8	24.1	17.1	9.9	-	30.8	3.9	21.9	15.5	8.7	-	25.2	4.0	19.0	12.9	7.4	-							
	67	37.2	3.4	34.1	25.8	17.9	10.5	33.2	3.6	31.3	23.9	16.1	9.2	29.1	3.8	28.5	22.0	14.3	8.0	24.1	3.9	23.6	18.5	12.5	6.6							
	62	36.5	3.4	36.5	33.3	27.2	17.4	32.8	3.7	32.4	30.1	24.8	15.6	28.4	3.9	28.4	26.7	22.2	13.7	23.6	4.0	23.6	22.1	19.3	11.9							
	57	36.4	3.4	36.4	34.0	31.6	24.4	32.7	3.7	32.3	30.7	27.9	22.3	28.3	3.9	28.3	27.2	24.3	19.9	23.5	4.0	23.5	22.5	20.5	17.1							
900	72	38.3	3.5	21.9	16.0	10.6	-	34.1	3.8	19.8	14.7	9.3	-	29.4	3.9	17.8	13.3	8.2	-	24.1	4.0	15.5	11.1	6.8	-							
	67	35.2	3.4	27.9	21.7	15.8	10.2	31.4	3.7	25.4	20.2	14.1	9.0	27.0	3.8	22.9	18.3	12.5	7.7	22.2	3.9	20.0	15.4	10.7	6.3							
	62	33.0	3.3	33.0	27.6	21.3	15.3	29.6	3.5	29.2	25.6	19.2	13.7	25.6	3.6	25.6	23.5	17.2	12.0	21.2	3.8	21.2	19.6	14.9	10.2							
	57	33.0	3.3	33.0	30.8	27.3	20.9	29.6	3.6	29.2	27.9	24.9	19.0	25.6	3.7	25.6	24.7	21.7	16.8	21.2	3.8	21.2	20.2	18.8	14.5							

1. These capacities are gross ratings. For net capacity, determine the kW of the supply air blower motor from the SUPPLY AIR BLOWER PERFORMANCE Table, multiply this value by 3.415 MBH/kW to determine the motor heat, and deduct this heat from the gross capacity of the unit.
2. These ratings include the compressor and the condensate fan motors but not the supply air blower motor. The total condenser fan motor power input is 0.46kW. Refer to the SUPPLY AIR BLOWER PERFORMANCE Table for the kW of the supply air blower motor.

NOTE: Shaded areas indicate nominal ratings

TABLE 5: DC048 COOLING CAPACITIES (4 TON)

Air On Evap.		M ³ /S																							
		Temperature of Air on Condenser Coil																							
		35°C				41°C				46°C				52°C											
M ³ /S	WB (°C)	Total Cap. ¹ (kW)	Tot. Input ² (kW)	Sensible Capacity				Total Cap. ¹ (kW)	Tot. Input ² (kW)	Sensible Capacity				Total Cap. ¹ (kW)	Tot. Input ² (kW)	Sensible Capacity				Total Cap. ¹ (kW)	Tot. Input ² (kW)	Sensible Capacity			
				Return Dry Bulb (°C)						Return Dry Bulb (°C)						Return Dry Bulb (°C)						Return Dry Bulb (°C)			
				31	28	25	22			31	28	25	22			31	28	25	22			31	28	25	22
0.95	23	15.4	4.5	11.5	7.5	4.0	-	13.7	4.8	10.5	7.0	3.5	-	11.8	5.1	9.6	6.3	3.1	-	9.9	5.2	8.4	5.3	2.6	-
	20	14.9	4.4	14.9	11.3	7.2	3.6	13.4	4.7	13.2	10.5	6.6	3.2	11.6	5.0	11.6	9.6	5.8	2.8	9.4	5.1	9.4	8.2	5.0	2.3
	17	14.8	4.4	14.8	13.8	11.0	6.9	13.3	4.7	13.2	11.9	10.0	6.2	11.5	5.0	11.5	11.1	9.0	5.5	9.4	5.1	9.4	9.1	7.9	4.8
	14	14.8	4.4	14.8	13.8	12.8	10.7	13.3	4.7	13.2	11.9	11.3	9.7	11.5	5.0	11.5	11.1	9.8	8.7	9.4	5.1	9.4	9.0	8.3	7.6
0.75	23	15.0	4.4	9.9	6.7	3.8	-	13.4	4.7	9.0	6.2	3.3	-	11.5	4.9	8.2	5.6	2.9	-	9.4	5.1	7.1	4.7	2.5	-
	20	13.9	4.3	13.2	9.8	6.5	3.5	12.4	4.6	12.1	9.0	5.9	3.1	10.9	4.9	11.0	8.3	5.2	2.7	9.0	5.0	9.1	7.0	4.6	2.2
	17	14.0	4.3	14.0	13.0	9.6	6.3	12.6	4.6	12.4	11.8	8.7	5.6	10.9	4.9	10.9	10.5	7.8	5.0	9.0	5.0	9.0	8.7	6.8	4.3
	14	14.0	4.3	14.0	13.0	12.1	9.4	12.5	4.6	12.4	11.8	10.7	8.5	10.9	4.9	10.9	10.4	9.3	7.6	9.0	5.0	9.0	8.6	7.9	6.6
0.55	23	14.4	4.3	8.2	5.8	3.6	-	12.8	4.6	7.4	5.3	3.1	-	11.1	4.8	6.6	4.8	2.7	-	9.1	4.9	5.8	4.0	2.3	-
	20	13.2	4.2	10.7	8.2	5.7	3.4	11.8	4.5	9.8	7.6	5.1	3.0	10.2	4.7	8.8	6.9	4.5	2.6	8.4	4.9	7.7	5.8	3.8	2.1
	17	12.7	4.2	12.7	10.7	8.1	5.5	11.4	4.4	11.3	9.9	7.3	5.0	9.9	4.6	9.9	9.1	6.5	4.4	8.2	4.8	8.2	7.6	5.6	3.7
	14	12.7	4.2	12.7	11.9	10.6	7.9	11.4	4.5	11.3	10.7	9.6	7.2	9.9	4.7	9.9	9.5	8.4	6.4	8.2	4.9	8.2	7.8	7.3	5.5

Air On Evap.		CFM																							
		Temperature of Air on Condenser Coil																							
		95°F				105°F				115°F				125°F											
CFM	WB (°F)	Total Cap. ¹ (MBH)	Tot. Input ² (kW)	Sensible Capacity				Total Cap. ¹ (MBH)	Tot. Input ² (kW)	Sensible Capacity				Total Cap. ¹ (MBH)	Tot. Input ² (kW)	Sensible Capacity				Total Cap. ¹ (MBH)	Tot. Input ² (kW)	Sensible Capacity			
				Return Dry Bulb (°F)						Return Dry Bulb (°F)						Return Dry Bulb (°F)						Return Dry Bulb (°F)			
				86	80	74	68			86	80	74	68			86	80	74	68			86	80	74	68
2000	72	52.5	4.5	39.4	25.7	13.6	-	46.7	4.8	36.0	23.8	12.1	-	40.4	5.1	32.7	21.6	10.6	-	33.6	5.2	28.6	18.0	9.0	-
	67	50.7	4.4	50.7	38.7	24.7	12.4	45.6	4.7	45.0	35.9	22.3	11.0	39.4	5.0	39.4	32.8	19.9	9.5	32.1	5.1	32.1	27.9	17.2	7.9
	62	50.6	4.4	50.6	47.2	37.6	23.7	45.4	4.7	44.9	40.5	34.0	21.3	39.4	5.0	39.4	37.9	30.7	18.8	32.1	5.1	32.1	31.0	26.8	16.3
	57	50.6	4.4	50.6	47.1	43.7	36.4	45.4	4.7	44.9	40.4	38.6	33.1	39.3	5.0	39.3	37.8	33.6	29.6	32.1	5.1	32.1	30.9	28.3	25.8
1600	72	51.2	4.4	33.9	23.0	12.8	-	45.6	4.7	30.8	21.2	11.4	-	39.4	4.9	28.0	19.2	9.9	-	32.2	5.1	24.3	16.1	8.4	-
	67	47.5	4.3	45.0	33.3	22.3	12.0	42.3	4.6	41.3	30.8	20.1	10.6	37.1	4.9	37.6	28.4	17.8	9.2	30.7	5.0	31.1	23.9	15.5	7.6
	62	47.7	4.3	47.7	44.5	32.7	21.4	42.9	4.6	42.4	40.3	29.8	19.2	37.1	4.9	37.1	35.7	26.7	16.9	30.9	5.0	30.9	29.5	23.3	14.6
	57	47.6	4.3	47.6	44.4	41.3	31.9	42.8	4.6	42.3	40.1	36.5	29.2	37.0	4.9	37.0	35.6	31.7	25.9	30.8	5.0	30.8	29.4	26.8	22.3
1200	72	49.2	4.3	27.9	19.7	12.1	-	43.8	4.6	25.2	18.1	10.7	-	37.7	4.8	22.6	16.4	9.4	-	31.0	4.9	19.8	13.6	7.8	-
	67	45.2	4.2	36.7	27.8	19.3	11.7	40.3	4.5	33.4	25.9	17.2	10.3	34.6	4.7	30.0	23.5	15.3	8.9	28.6	4.9	26.2	19.7	13.1	7.3
	62	43.4	4.2	43.4	36.6	27.5	18.9	38.9	4.4	38.4	33.8	24.8	16.9	33.7	4.6	33.7	31.0	22.2	14.9	27.9	4.8	27.9	25.9	19.3	12.6
	57	43.4	4.2	43.4	40.5	36.1	27.0	38.9	4.5	38.4	36.7	32.9	24.5	33.7	4.7	33.7	32.5	28.7	21.7	27.9	4.9	27.9	26.5	24.9	18.7

1. These capacities are gross ratings. For net capacity, determine the kW of the supply air blower motor from the SUPPLY AIR BLOWER PERFORMANCE Table, multiply this value by 3.415 MBH/kW to determine the motor heat, and deduct this heat from the gross capacity of the unit.
2. These ratings include the compressor and the condensate fan motors but not the supply air blower motor. The total condenser fan motor power input is 0.46kW. Refer to the SUPPLY AIR BLOWER PERFORMANCE Table for the kW of the supply air blower motor.

NOTE: Shaded areas indicate nominal ratings

TABLE 6: DC060 COOLING CAPACITIES (5 TON)

Air On Evap.		M ³ /S																							
		Temperature of Air on Condenser Coil																							
		35°C					41°C					46°C					52°C								
M ³ /S	WB (°C)	Total Cap. ¹ (kW)	Tot. Input ² (kW)	Sensible Capacity				Total Cap. ¹ (kW)	Tot. Input ² (kW)	Sensible Capacity				Total Cap. ¹ (kW)	Tot. Input ² (kW)	Sensible Capacity				Total Cap. ¹ (kW)	Tot. Input ² (kW)	Sensible Capacity			
				Return Dry Bulb (°C)						Return Dry Bulb (°C)						Return Dry Bulb (°C)						Return Dry Bulb (°C)			
				31	28	25	22			31	28	25	22			31	28	25	22			31	28	25	22
1.15	23	20.7	6.1	15.2	10.5	5.8	-	18.4	6.4	13.9	9.7	5.1	-	15.9	6.8	12.6	8.8	4.5	-	13.2	7.0	11.1	7.4	3.8	-
	20	19.8	6.0	19.8	15.1	9.9	5.3	17.8	6.3	17.6	14.0	8.9	4.7	15.4	6.7	15.4	12.8	7.9	4.1	12.6	6.9	12.6	10.9	6.9	3.4
	17	19.8	6.0	19.8	18.8	14.4	9.5	17.8	6.3	17.6	16.1	13.0	8.5	15.4	6.7	15.4	15.1	11.8	7.5	12.6	6.9	12.6	12.3	10.3	6.5
	14	19.8	6.0	19.8	18.8	17.1	13.9	17.7	6.3	17.5	16.1	15.1	12.6	15.4	6.7	15.4	15.1	13.2	11.3	12.5	6.9	12.5	12.3	11.1	9.9
0.95	23	20.2	6.1	13.5	9.6	5.5	-	18.0	6.4	12.3	8.9	4.9	-	15.5	6.7	11.2	8.1	4.3	-	12.7	6.9	9.7	6.7	3.6	-
	20	18.8	5.9	17.6	13.5	9.2	5.2	16.7	6.2	16.1	12.5	8.2	4.6	14.7	6.6	14.7	11.5	7.3	4.0	12.1	6.8	12.1	9.7	6.4	3.3
	17	18.8	5.9	18.8	17.9	12.9	8.8	16.9	6.2	16.7	16.2	11.8	7.9	14.7	6.6	14.7	14.4	10.5	7.0	12.2	6.8	12.2	11.9	9.2	6.0
	14	18.8	5.9	18.8	17.9	16.3	12.5	16.9	6.2	16.7	16.2	14.4	11.5	14.6	6.6	14.6	14.4	12.5	10.2	12.2	6.8	12.2	11.9	10.6	8.8
0.75	23	19.6	6.0	11.9	8.6	5.3	-	17.5	6.3	10.7	8.0	4.7	-	15.0	6.6	9.6	7.2	4.1	-	12.3	6.8	8.4	6.0	3.4	-
	20	18.1	5.8	15.2	11.8	8.3	5.1	16.1	6.1	13.8	11.0	7.4	4.5	13.9	6.4	12.4	10.0	6.6	3.8	11.4	6.6	10.9	8.4	5.6	3.1
	17	17.6	5.8	17.6	15.3	11.5	8.1	15.8	6.0	15.6	14.2	10.3	7.2	13.6	6.3	13.6	13.0	9.3	6.3	11.3	6.5	11.3	10.9	8.0	5.4
	14	17.5	5.7	17.5	16.7	14.8	11.1	15.7	6.0	15.5	15.1	13.5	10.1	13.6	6.3	13.6	13.4	11.8	9.0	11.3	6.5	11.3	10.9	10.2	7.7

Air On Evap.		CFM																							
		Temperature of Air on Condenser Coil																							
		95°F					105°F					115°F					125°F								
CFM	WB (°F)	Total Cap. ¹ (MBH)	Tot. Input ² (kW)	Sensible Capacity				Total Cap. ¹ (MBH)	Tot. Input ² (kW)	Sensible Capacity				Total Cap. ¹ (MBH)	Tot. Input ² (kW)	Sensible Capacity				Total Cap. ¹ (MBH)	Tot. Input ² (kW)	Sensible Capacity			
				Return Dry Bulb (°F)						Return Dry Bulb (°F)						Return Dry Bulb (°F)						Return Dry Bulb (°F)			
				86	80	74	68			86	80	74	68			86	80	74	68			86	80	74	68
2400	72	70.5	6.1	52.0	35.8	19.7	-	62.8	6.4	47.5	33.2	17.5	-	54.2	6.8	43.1	30.1	15.4	-	45.2	7.0	37.7	25.1	13.0	-
	67	67.7	6.0	67.7	51.6	33.7	18.1	60.8	6.3	60.1	47.9	30.5	16.1	52.6	6.7	52.6	43.8	27.1	13.9	42.8	6.9	42.8	37.1	23.4	11.5
	62	67.6	6.0	67.6	64.2	49.2	32.3	60.6	6.3	59.9	55.1	44.5	29.1	52.5	6.7	52.5	51.5	40.1	25.7	42.9	6.9	42.9	42.1	35.1	22.2
	57	67.5	6.0	67.5	64.2	58.5	47.4	60.5	6.3	59.8	55.1	51.5	43.1	52.4	6.7	52.4	51.4	44.9	38.6	42.8	6.9	42.8	42.0	37.9	33.6
2000	72	68.9	6.1	46.1	32.9	18.9	-	61.4	6.4	41.9	30.4	16.7	-	52.9	6.7	38.0	27.5	14.6	-	43.3	6.9	33.0	23.0	12.4	-
	67	64.1	5.9	59.9	46.0	31.3	17.7	57.1	6.2	55.0	42.6	28.1	15.6	50.1	6.6	50.1	39.2	25.0	13.5	41.4	6.8	41.4	33.0	21.8	11.1
	62	64.3	5.9	64.3	61.2	44.0	30.1	57.8	6.2	57.1	55.4	40.2	27.0	50.0	6.6	50.0	49.1	36.0	23.8	41.6	6.8	41.6	40.5	31.4	20.5
	57	64.2	5.9	64.2	61.1	55.7	42.8	57.7	6.2	57.0	55.2	49.2	39.1	49.9	6.6	49.9	49.0	42.8	34.8	41.5	6.8	41.5	40.5	36.1	30.0
1600	72	66.9	6.0	40.6	29.5	18.0	-	59.6	6.3	36.6	27.1	15.9	-	51.3	6.6	32.9	24.5	13.9	-	42.1	6.8	28.7	20.4	11.6	-
	67	61.7	5.8	51.9	40.4	28.3	17.3	55.0	6.1	47.2	37.6	25.3	15.2	47.3	6.4	42.4	34.0	22.5	13.1	38.9	6.6	37.1	28.6	19.2	10.7
	62	59.9	5.8	59.9	52.2	39.1	27.5	53.8	6.0	53.1	48.3	35.3	24.6	46.6	6.3	46.6	44.3	31.6	21.6	38.6	6.5	38.6	37.0	27.4	18.4
	57	59.8	5.7	59.8	57.0	50.4	38.0	53.7	6.0	53.0	51.5	46.0	34.6	46.5	6.3	46.5	45.7	40.1	30.6	38.5	6.5	38.5	37.3	34.8	26.4

1. These capacities are gross ratings. For net capacity, determine the kW of the supply air blower motor from the SUPPLY AIR BLOWER PERFORMANCE Table, multiply this value by 3.415 MBH/kW to determine the motor heat, and deduct this heat from the gross capacity of the unit.
2. These ratings include the compressor and the condensate fan motors but not the supply air blower motor. The total condenser fan motor power input is 0.46kW. Refer to the SUPPLY AIR BLOWER PERFORMANCE Table for the kW of the supply air blower motor.

NOTE: Shaded areas indicate nominal ratings

TABLE 7: DC076 COOLING CAPACITIES (6.3 TON)

Air On Evap.		M ³ /S																							
		Temperature of Air on Condenser Coil																							
		35°C				41°C				46°C				52°C											
M ³ /S	WB (°C)	Total Cap. ¹ (kW)	Tot. Input ² (kW)	Sensible Capacity				Total Cap. ¹ (kW)	Tot. Input ² (kW)	Sensible Capacity				Total Cap. ¹ (kW)	Tot. Input ² (kW)	Sensible Capacity				Total Cap. ¹ (kW)	Tot. Input ² (kW)	Sensible Capacity			
				Return Dry Bulb (°C)						Return Dry Bulb (°C)						Return Dry Bulb (°C)						Return Dry Bulb (°C)			
				31	28	25	22			31	28	25	22			31	28	25	22			31	28	25	22
1.40	23	23.9	7.7	18.7	13.6	8.9	-	21.2	8.2	17.0	12.6	7.9	-	18.3	8.6	15.5	11.5	6.9	-	15.3	8.9	13.5	9.6	5.9	-
	20	23.2	7.6	23.2	17.9	13.0	8.1	20.9	8.1	20.6	16.6	11.7	7.2	18.1	8.5	18.1	15.1	10.4	6.2	14.7	8.8	14.7	12.9	9.0	5.1
	17	23.2	7.6	23.2	21.7	17.2	12.4	20.8	8.1	20.6	18.6	15.5	11.1	18.0	8.5	18.0	17.4	14.0	9.8	14.7	8.8	14.7	14.2	12.2	8.5
	14	23.2	7.6	23.2	21.6	20.1	16.5	20.8	8.1	20.5	18.6	17.7	15.0	18.0	8.5	18.0	17.3	15.4	13.4	14.7	8.8	14.7	14.2	13.0	11.7
1.15	23	23.2	7.6	16.7	12.7	8.4	-	20.7	8.1	15.2	11.7	7.5	-	17.9	8.4	13.8	10.6	6.6	-	14.6	8.6	12.0	8.9	5.6	-
	20	21.6	7.3	20.2	16.2	12.1	7.9	19.2	7.8	18.6	15.0	10.9	6.9	16.9	8.2	16.9	13.8	9.7	6.0	14.0	8.5	14.0	11.6	8.4	5.0
	17	21.9	7.4	21.9	20.4	15.6	11.5	19.7	7.9	19.4	18.5	14.2	10.3	17.0	8.3	17.0	16.4	12.7	9.1	14.2	8.6	14.2	13.6	11.1	7.8
	14	21.8	7.4	21.8	20.4	19.0	15.0	19.6	7.9	19.4	18.4	16.8	13.7	17.0	8.3	17.0	16.4	14.6	12.2	14.1	8.6	14.1	13.5	12.3	10.5
0.85	23	22.2	7.5	14.6	11.5	8.0	-	19.8	8.0	13.2	10.6	7.1	-	17.1	8.3	11.8	9.5	6.2	-	14.0	8.5	10.3	7.9	5.2	-
	20	20.5	7.2	17.3	14.2	11.0	7.6	18.3	7.7	15.8	13.2	9.8	6.7	15.7	8.0	14.2	12.0	8.7	5.8	12.9	8.3	12.4	10.1	7.4	4.7
	17	20.0	7.2	20.0	16.9	13.8	10.5	17.9	7.5	17.7	15.7	12.4	9.4	15.5	7.9	15.5	14.4	11.1	8.3	12.9	8.1	12.9	12.0	9.6	7.0
	14	19.9	7.1	19.9	18.7	16.4	13.2	17.9	7.6	17.7	16.9	14.9	12.0	15.5	7.9	15.5	15.0	13.0	10.7	12.8	8.2	12.8	12.2	11.3	9.2

Air On Evap.		CFM																							
		Temperature of Air on Condenser Coil																							
		95°F				105°F				115°F				125°F											
CFM	WB (°F)	Total Cap. ¹ (MBH)	Tot. Input ² (kW)	Sensible Capacity				Total Cap. ¹ (MBH)	Tot. Input ² (kW)	Sensible Capacity				Total Cap. ¹ (MBH)	Tot. Input ² (kW)	Sensible Capacity				Total Cap. ¹ (MBH)	Tot. Input ² (kW)	Sensible Capacity			
				Return Dry Bulb (°F)						Return Dry Bulb (°F)						Return Dry Bulb (°F)						Return Dry Bulb (°F)			
				86	80	74	68			86	80	74	68			86	80	74	68			86	80	74	68
3000	72	81.4	7.7	63.6	46.5	30.3	-	72.5	8.2	58.1	43.1	26.9	-	62.6	8.6	52.8	39.1	23.7	-	52.1	8.9	46.2	32.6	20.0	-
	67	79.2	7.6	79.2	60.9	44.2	27.6	71.2	8.1	70.4	56.5	40.0	24.5	61.6	8.5	61.6	51.7	35.6	21.1	50.1	8.8	50.1	43.9	30.7	17.5
	62	79.2	7.6	79.2	73.9	58.6	42.2	71.0	8.1	70.2	63.4	53.0	38.0	61.5	8.5	61.5	59.3	47.7	33.5	50.2	8.8	50.2	48.5	41.7	29.0
	57	79.1	7.6	79.1	73.8	68.6	56.3	70.9	8.1	70.1	63.3	60.4	51.1	61.4	8.5	61.4	59.2	52.7	45.8	50.1	8.8	50.1	48.3	44.4	39.9
2400	72	79.2	7.6	57.1	43.3	28.8	-	70.6	8.1	52.0	39.9	25.6	-	60.9	8.4	47.2	36.1	22.4	-	49.8	8.6	41.0	30.2	19.0	-
	67	73.7	7.3	69.1	55.2	41.4	26.9	65.7	7.8	63.4	51.1	37.2	23.7	57.6	8.2	57.7	47.1	33.0	20.5	47.6	8.5	47.7	39.6	28.8	16.9
	62	74.7	7.4	74.7	69.7	53.1	39.2	67.1	7.9	66.3	63.1	48.4	35.2	58.1	8.3	58.1	55.9	43.4	31.0	48.3	8.6	48.3	46.2	37.8	26.8
	57	74.5	7.4	74.5	69.6	64.9	51.1	66.9	7.9	66.1	62.9	57.3	46.7	57.9	8.3	57.9	55.9	49.8	41.5	48.1	8.6	48.1	46.2	42.1	35.8
1800	72	75.9	7.5	49.8	39.2	27.4	-	67.6	8.0	44.9	36.1	24.1	-	58.2	8.3	40.3	32.5	21.1	-	47.8	8.5	35.2	27.1	17.7	-
	67	69.8	7.2	59.1	48.5	37.5	26.0	62.3	7.7	53.8	45.2	33.5	22.9	53.5	8.0	48.3	40.9	29.8	19.6	44.1	8.3	42.2	34.4	25.4	16.1
	62	68.2	7.2	68.2	57.8	46.9	36.0	61.2	7.5	60.5	53.5	42.3	32.2	53.0	7.9	53.0	49.1	37.9	28.3	43.9	8.1	43.9	41.0	32.8	24.0
	57	68.0	7.1	68.0	63.7	55.9	45.2	61.0	7.6	60.3	57.6	50.9	41.1	52.8	7.9	52.8	51.1	44.4	36.4	43.7	8.2	43.7	41.7	38.6	31.4

1. These capacities are gross ratings. For net capacity, determine the kW of the supply air blower motor from the SUPPLY AIR BLOWER PERFORMANCE Table, multiply this value by 3.415 MBH/kW to determine the motor heat, and deduct this heat from the gross capacity of the unit.
2. These ratings include the compressor and the condensate fan motors but not the supply air blower motor. The total condenser fan motor power input is 0.46kW. Refer to the SUPPLY AIR BLOWER PERFORMANCE Table for the kW of the supply air blower motor.

NOTE: Shaded areas indicate nominal ratings

TABLE 8: SUPPLY AIR BLOWER PERFORMANCE (3 & 4 TON DIRECT DRIVE) - SIDE DUCT APPLICATION

M³/S											
UNIT TONNAGE	MOTOR SPEED	AVAILABLE EXTERNAL STATIC PRESSURE-Pa*									
		50		74		99		124		149	
		M ³ /S	WATTS	M ³ /S	WATTS	M ³ /S	WATTS	M ³ /S	WATTS	M ³ /S	WATTS
3 ¹	HI	-	-	-	-	0.80	825	0.78	785	0.74	755
	MED	0.79	800	0.77	780	0.75	750	0.72	720	0.67	690
	LOW	0.70	710	0.69	690	0.67	670	0.64	650	0.62	620
4 ¹	HI	0.94	960	0.91	936	0.88	910	0.85	880	0.81	845
	MED	0.85	838	0.83	810	0.80	785	0.78	765	0.75	735
	LOW	0.79	760	0.77	738	0.76	715	0.73	695	0.70	670

M³/S											
UNIT TONNAGE	MOTOR SPEED	AVAILABLE EXTERNAL STATIC PRESSURE-Pa*									
		174		198		223		248			
		M ³ /S	WATTS	M ³ /S	WATTS	M ³ /S	WATTS	M ³ /S	WATTS	M ³ /S	WATTS
3 ¹	HI	0.67	725	0.64	700	0.60	680	0.56	655		
	MED	0.62	650	0.59	630	0.59	610	0.52	590		
	LOW	0.59	605	0.56	590	0.55	570	0.48	545		
4 ¹	HI	0.77	820	0.73	790	0.67	765	0.61	740		
	MED	0.71	705	0.66	675	0.61	645	0.56	625		
	LOW	0.67	645	0.63	620	0.58	595	0.53	575		

CFM											
UNIT TONNAGE	MOTOR SPEED	AVAILABLE EXTERNAL STATIC PRESSURE-IWG*									
		0.20		0.30		0.40		0.50		0.60	
		CFM	WATTS	CFM	WATTS	CFM	WATTS	CFM	WATTS	CFM	WATTS
3 ¹	HI	-	-	-	-	1699	825	1650	785	1570	755
	MED	1684	800	1631	780	1582	750	1524	720	1410	690
	LOW	1487	710	1464	690	1421	670	1367	650	1315	620
4 ¹	HI	1996	960	1933	936	1868	910	1795	880	1722	845
	MED	1804	838	1765	810	1714	785	1650	765	1589	735
	LOW	1681	760	1640	738	1604	715	1541	695	1490	670

CFM											
UNIT TONNAGE	MOTOR SPEED	AVAILABLE EXTERNAL STATIC PRESSURE-IWG*									
		0.70		0.80		0.90		1.00			
		CFM	WATTS	CFM	WATTS	CFM	WATTS	CFM	WATTS	CFM	WATTS
3 ¹	HI	1430	725	1360	700	1280	680	1180	655		
	MED	1324	650	1260	630	1185	610	1100	590		
	LOW	1246	605	1185	590	1110	570	1020	545		
4 ¹	HI	1635	820	1544	790	1419	765	1300	740		
	MED	1508	705	1407	675	1306	645	1195	625		
	LOW	1416	645	1337	620	1230	595	1120	575		

1. Side Duct application (380/415 Volts)

* . Includes allowances for a wet evaporator coil, 25mm [1 in] filters, and the heat exchangers. Refer to STATIC RESISTANCES Table for resistance values on applications other than gas/electric units with side duct airflows.

TABLE 9: SUPPLY AIR BLOWER PERFORMANCE (5 TON BELT DRIVE) - SIDE DUCT APPLICATION

		M³/S													
UNIT TONNAGE	AIR FLOW M ³ /S	AVAILABLE EXTERNAL STATIC PRESSURE-Pa*													
		50		74		99		124		149		174		198	
		RPM	WATTS	RPM	WATTS	RPM	WATTS	RPM	WATTS	RPM	WATTS	RPM	WATTS	RPM	WATTS
5 ¹	1.18	1059	1560	1077	1590	1095	1630	1114	1650	1134	1660	1158	1685	-	-
	1.13	1032	1405	1054	1470	1074	1525	1094	1560	1116	1595	1140	1620	1167	1640
	1.08	1005	1260	1024	1275	1049	1370	1069	1440	1090	1475	1116	1505	1142	1535
	1.04	980	1160	1002	1170	1022	1190	1044	1250	1066	1350	1090	1410	1117	1440
	0.99	930	1060	957	1070	983	1080	1010	1100	1039	1160	1064	1260	1092	1340
	0.94	877	950	908	975	941	1000	976	1020	1009	1050	1040	1100	1070	1225
	0.90	-	-	-	-	894	885	940	940	980	980	1014	1020	1047	1095
	0.85	-	-	-	-	855	815	903	860	950	905	988	940	1022	970
	0.80	-	-	-	-	-	-	884	815	925	850	964	880	1001	910
	0.75	-	-	-	-	-	-	864	770	908	805	948	835	987	870
0.71	-	-	-	-	-	-	-	-	882	740	926	780	965	830	

		CFM													
UNIT TONNAGE	AIR FLOW CFM	AVAILABLE EXTERNAL STATIC PRESSURE- <i>iwg</i> *													
		0.20		0.30		0.40		0.50		0.60		0.70		0.80	
		RPM	WATTS	RPM	WATTS	RPM	WATTS	RPM	WATTS	RPM	WATTS	RPM	WATTS	RPM	WATTS
5 ¹	2500	1059	1560	1077	1590	1095	1630	1114	1650	1134	1660	1158	1685	-	-
	2400	1032	1405	1054	1470	1074	1525	1094	1560	1116	1595	1140	1620	1167	1640
	2300	1005	1260	1024	1275	1049	1370	1069	1440	1090	1475	1116	1505	1142	1535
	2200	980	1160	1002	1170	1022	1190	1044	1250	1066	1350	1090	1410	1117	1440
	2100	930	1060	957	1070	983	1080	1010	1100	1039	1160	1064	1260	1092	1340
	2000	877	950	908	975	941	1000	976	1020	1009	1050	1040	1100	1070	1225
	1900	-	-	-	-	894	885	940	940	980	980	1014	1020	1047	1095
	1800	-	-	-	-	855	815	903	860	950	905	988	940	1022	970
	1700	-	-	-	-	-	-	884	815	925	850	964	880	1001	910
	1600	-	-	-	-	-	-	864	770	908	805	948	835	987	870
1500	-	-	-	-	-	-	-	-	882	740	926	780	965	830	

		CFM													
UNIT TONNAGE	AIR FLOW CFM	AVAILABLE EXTERNAL STATIC PRESSURE- <i>iwg</i> *													
		0.90		1.00		1.10		1.20		1.30		1.40		1.50	
		RPM	WATTS	RPM	WATTS	RPM	WATTS	RPM	WATTS	RPM	WATTS	RPM	WATTS	RPM	WATTS
5 ¹	2500	-	-	-	-	-	-	-	-	-	-	-	-	-	-
	2400	-	-	-	-	-	-	-	-	-	-	-	-	-	-
	2300	1170	1580	-	-	-	-	-	-	-	-	-	-	-	-
	2200	1148	1480	1180	1530	-	-	-	-	-	-	-	-	-	-
	2100	1121	1385	1155	1425	-	-	-	-	-	-	-	-	-	-
	2000	1100	1285	1133	1340	1169	1385	-	-	-	-	-	-	-	-
	1900	1079	1180	1110	1240	1143	1280	1178	1330	-	-	-	-	-	-
	1800	1058	1060	1090	1135	1122	1190	1158	1240	-	-	-	-	-	-
	1700	1035	960	1071	1030	1103	1100	1134	1140	1164	1175	-	-	-	-
	1600	1020	900	1056	965	1088	1035	1118	1065	1145	1105	1170	1130	-	-
1500	1004	860	1038	880	1070	925	1101	980	1130	1045	1158	1075	-	-	

1. Side duct application (380/415 Volts)
 * . Includes allowances for a wet evaporator coil, 25mm [1in] filters, and the heat exchangers. Refer to STATIC RESISTANCE Table for resistance values on applications other than gas / electric units with side duct airflows.

TABLE 10: SUPPLY AIR BLOWER PERFORMANCE (6.3 TON BELT DRIVE) - SIDE DUCT APPLICATION

		M³/S													
UNIT TONNAGE	AIR FLOW M ³ /S	AVAILABLE EXTERNAL STATIC PRESSURE-Pa*													
		50		74		99		124		149		174		198	
		RPM	WATTS	RPM	WATTS	RPM	WATTS	RPM	WATTS	RPM	WATTS	RPM	WATTS	RPM	WATTS
6.3 ¹	1.50	1150	2325	1182	2425	-	-	-	-	-	-	-	-	-	-
	1.42	1100	2010	1129	2090	1157	2150	1185	2225	-	-	-	-	-	-
	1.32	1045	1700	1074	1780	1102	1850	1131	1940	1160	2025	1190	2075	-	-
	1.23	985	1425	1015	1475	1045	1540	1075	1630	1103	1715	1135	1760	1163	1825
	1.13	930	1240	958	1300	990	1350	1020	1400	1051	1430	1081	1490	1111	1600
	1.04	-	-	905	1070	933	1160	965	1210	997	1250	1028	1285	1060	1325
	0.94	-	-	-	-	-	-	919	1025	950	1100	982	1130	1014	1160
	0.85	-	-	-	-	-	-	-	-	909	925	939	1005	968	1030

		AVAILABLE EXTERNAL STATIC PRESSURE-Pa*													
UNIT TONNAGE	AIR FLOW M ³ /S	223		248		273		298		322		347		372	
		RPM	WATTS	RPM	WATTS	RPM	WATTS	RPM	WATTS	RPM	WATTS	RPM	WATTS	RPM	WATTS
		6.3 ¹	1.50	-	-	-	-	-	-	-	-	-	-	-	-
1.42	-		-	-	-	-	-	-	-	-	-	-	-	-	-
1.32	-		-	-	-	-	-	-	-	-	-	-	-	-	-
1.23	1193		1920	-	-	-	-	-	-	-	-	-	-	-	-
1.13	1142		1675	1173	1730	-	-	-	-	-	-	-	-	-	-
1.04	1090		1380	1124	1450	1155	1550	1186	1640	-	-	-	-	-	-
0.94	1045		1175	1077	1200	1109	1275	1140	1360	1170	1460	-	-	-	-
0.85	998		1050	1028	1060	1058	1060	1087	1075	1118	1150	1148	1250	1176	1360

		AVAILABLE EXTERNAL STATIC PRESSURE-1WG*													
UNIT TONNAGE	AIR FLOW CFM	0.20		0.30		0.40		0.50		0.60		0.70		0.80	
		RPM	WATTS	RPM	WATTS	RPM	WATTS	RPM	WATTS	RPM	WATTS	RPM	WATTS	RPM	WATTS
		6.3 ¹	3200	1150	2325	1182	2425	-	-	-	-	-	-	-	-
3000	1100		2010	1129	2090	1157	2150	1185	2225	-	-	-	-	-	-
2800	1045		1700	1074	1780	1102	1850	1131	1940	1160	2025	1190	2075	-	-
2600	985		1425	1015	1475	1045	1540	1075	1630	1103	1715	1135	1760	1163	1825
2400	930		1240	958	1300	990	1350	1020	1400	1051	1430	1081	1490	1111	1600
2200	-		-	905	1070	933	1160	965	1210	997	1250	1028	1285	1060	1325
2000	-		-	-	-	-	-	919	1025	950	1100	982	1130	1014	1160
1800	-		-	-	-	-	-	-	-	909	925	939	1005	968	1030

		AVAILABLE EXTERNAL STATIC PRESSURE-1WG*													
UNIT TONNAGE	AIR FLOW CFM	0.90		1.00		1.10		1.20		1.30		1.40		1.50	
		RPM	WATTS	RPM	WATTS	RPM	WATTS	RPM	WATTS	RPM	WATTS	RPM	WATTS	RPM	WATTS
		6.3 ¹	3200	-	-	-	-	-	-	-	-	-	-	-	-
3000	-		-	-	-	-	-	-	-	-	-	-	-	-	-
2800	-		-	-	-	-	-	-	-	-	-	-	-	-	-
2600	1193		1920	-	-	-	-	-	-	-	-	-	-	-	-
2400	1142		1675	1173	1730	-	-	-	-	-	-	-	-	-	-
2200	1090		1380	1124	1450	1155	1550	1186	1640	-	-	-	-	-	-
2000	1045		1175	1077	1200	1109	1275	1140	1360	1170	1460	-	-	-	-
1800	998		1050	1028	1060	1058	1060	1087	1075	1118	1150	1148	1250	1176	1360

1. Side duct application (380/415 Volts)

*. Includes allowances for a wet evaporator coil, 25mm [1in] filters, and the heat exchangers. Refer to STATIC RESISTANCE Table for resistance values on applications other than gas / electric units with side duct airflows.

TABLE 11: BELT DRIVE MOTOR AND DRIVE DATA

MODEL	BLOWER RANGE (RPM)	MOTOR ¹				ADJUSTABLE MOTOR PULLY				FIXED BLOWER PULLY				BELT			
		HP	RPM	FRAME SIZE	SERVICE FACTOR	DESIG-NATION	PITCH DIA.		BORE		PITCH DIA.		BORE		PITCH LENGTH	DESIG-NATION	
							mm	inch	mm	inch	mm	inch	mm	inch			
5 TON	812-1102	1.5	1450	56	1.0	IVL44	69-97	2.8-3.8	22	7/8	127	5.0	25	1	922	36.3	A35
6 TON	948-1227	1.5	1450	56	1.0	IVM50	86-112	3.4-4.4	22	7/8	132	5.2	25	1	947	37.3	A36

1. All motors have solid bases and are inherently protected. These motors can be selected to operate into their service factor because they are located in the moving air, upstream of any heating device.

TABLE 12: STATIC RESISTANCES

DESCRIPTION	RESISTANCE, Pa											
	M ³ /S											
	0.47	0.57	0.66	0.75	0.85	0.94	1.03	1.13	1.23	1.32	1.42	
ECONOMIZER ^{1,3}	17.4	19.8	22.3	27.3	32.2	37.2	42.2	49.6	57.0	64.5	74.4	
ELECTRIC HEATERS ¹	7-15KW	10.0	12.4	14.9	17.4	19.8	24.8	29.8	34.7	39.7	47.1	54.6
	20-30KW	14.9	17.4	19.8	22.3	27.3	32.2	37.2	42.2	49.6	57.0	64.5
BOTTOM DUCT CONNECTIONS ¹	14.9	17.4	19.8	22.3	24.8	27.3	29.8	34.7	39.7	47.1	54.6	
COOLING ONLY ²	19.8	25.0	29.8	34.7	39.7	44.6	49.6	57.0	64.5	71.9	79.4	

DESCRIPTION	RESISTANCE, IWG											
	CFM											
	1000	1200	1400	1600	1800	2000	2200	2400	2600	2800	3000	
ECONOMIZER ^{1,3}	0.07	0.08	0.09	0.11	0.13	0.15	0.17	0.20	0.23	0.26	0.30	
ELECTRIC HEATERS ¹	7-15KW	0.04	0.05	0.06	0.07	0.08	0.10	0.12	0.14	0.16	0.19	0.22
	20-30KW	0.06	0.07	0.08	0.09	0.11	0.13	0.15	0.17	0.20	0.23	0.26
BOTTOM DUCT CONNECTIONS ¹	0.06	0.07	0.08	0.09	0.10	0.11	0.12	0.14	0.16	0.19	0.22	
COOLING ONLY ²	0.08	0.10	0.12	0.14	0.16	0.18	0.20	0.23	0.26	0.29	0.32	

1. Deduct these resistance values from the available external static pressure shown in SUPPLY AIR BLOWER PERFORMANCE Tables.
2. Add these resistance values to the available static resistance values on SUPPLY AIR BLOWER PERFORMANCE Tables.
3. The pressure through the economizer is greater for 100% outdoor air than for 100% return air. If the resistance of the return air duct system is less than 62.0 Pa [0.25 IWG], the unit will deliver less M³/S or CFM during full economizer operation.

TABLE 13: ELECTRIC HEATER SUPPLY AIR LIMITATIONS

UNIT MODEL SIZE NOMINAL TONS	VOLTAGE	MINIMUM SUPPLY AIR	HEATER SIZE NOMINAL KW				
			7	10	15	20	30
3	380/415-3-50	M ³ /S	0.47	0.57	0.57	0.61	-
		CFM	1100	1200	1200	1300	-
4	380/415-3-50	M ³ /S	0.61	0.61	0.61	0.61	-
		CFM	1300	1300	1300	1300	-
5	380/415-3-50	M ³ /S	0.75	0.75	0.75	0.75	0.75
		CFM	1600	1600	1600	1600	1600
6	380/415-3-50	M ³ /S	0.85	0.85	0.85	0.85	0.85
		CFM	1800	1800	1800	1800	1800

TABLE 14: ELECTRICAL DATA: 3 - 6.3 TON

Size (Tons)	Voltage	Compressors		OD Fan Motor FLA	ID Blower Motor FLA	Electric Heater Model No. ³	Heater KW	Heater Amps	Min. Circuit Ampacity (Amp)	Max Fuse / Brkr ¹ Size (Amps)
		RLA Each	LRA Each							
DC036 (3.0)	380-3-50	7.7	67	1.3	2.5	None	-	-	13.4	20
						2CE04510746 ²	4.3	6.5	13.4	20
						2CE04511046 ²	6.3	9.6	15.1	20
	415-3-50	7.7	67	1.3	2.5	None	-	-	13.4	20
						2CE04510746 ²	5.1	7.1	13.4	20
						2CE04511046 ²	7.5	10.4	16.2	20
DC048 (4.0)	380-3-50	9.9	79	1.3	4.24	None	-	-	17.9	25
						2CE04510746 ²	4.3	6.5	17.9	25
						2CE04511046 ²	6.3	9.6	17.9	25
	415-3-50	9.9	79	1.3	4.24	None	-	-	17.9	25
						2CE04510746 ²	5.1	7.1	17.9	25
						2CE04511046 ²	7.5	10.4	18.3	25
DC060 (5.0)	380-3-50	9.6	79	1.3	2.7	None	-	-	16	25
						2CE04510746 ²	4.3	6.5	16	25
						2CE04511046 ²	6.3	9.6	16	25
						2CE04511546 ²	8.5	12.9	19.5	25
						2CE04512046 ²	12.2	18.5	26.5	30
	415-3-50	9.6	79	1.3	2.7	None	-	-	16	25
						2CE04510746 ²	5.1	7.1	16	25
						2CE04511046 ²	7.5	10.4	16.4	25
						2CE04511546 ²	10.2	14.2	21.1	25
						2CE04512046 ²	14.6	20.3	28.8	30
DC076 (6.3)	380-3-50	16.7	90	1.3	2.7	None	-	-	41.6	50
						2CE04510746 ²	4.3	6.5	41.6	50
						2CE04511046 ²	6.3	9.6	41.6	50
						2CE04511546 ²	8.5	12.9	41.6	50
						2CE04512046 ²	12.2	18.5	41.6	50
	415-3-50	16.7	90	1.3	2.7	None	-	-	41.6	50
						2CE04510746 ²	5.1	7.1	41.6	50
						2CE04511046 ²	7.5	10.4	41.6	50
						2CE04511546 ²	10.2	14.2	41.6	50
						2CE04512046 ²	14.6	20.3	41.6	50

Note 1: HACR Type per NEC.

Note 2: These electric heaters DO NOT include a fuse box. If a fuse box is required to meet a local code, the fuse block accessory 2FB04700546 is available for field installation.

Note 3: Heaters are suitable for operation on 380/415V-3-50Hz power supply.

TABLE 15: PHYSICAL DATA

MODELS ¹		DC			
		036	048	060	076
EVAPORATOR BLOWER	Centrifugal Blower Dia. x Wd. mm (in)	305 X 254 (12 X 10)	305 X 254 (12 X 10)	305 X 254 (12 X 10)	305 X 254 (12 X 10)
	Fan Motor HP (Direct Drive)	1/3	3/4	----	----
	Fan Motor HP (Belt Drive)	----	----	1 1/2	1 1/2
EVAPORATOR COIL	Rows Deep	3	3	3	3
	Fins Per Inch (25 mm)	13	13	13	13
	Face Area m ² (ft. ²)	0.33 (3.6)	0.40 (4.3)	0.57 (5.1)	0.57 (5.1)
CONDENSER FANS	Propeller Dia. mm (in.)	610 (24)	610 (24)	610 (24)	610 (24)
	Fan Motor Hp	1/2	1/2	1/2	1/2
	Nom. CFM	4500	4500	4500	4500
CONDENSER COILS	Rows Deep	1	1	1	2
	Fins Per Inch (25 mm)	16	19	22	16
	Face Area m ² (ft. ²)	1.60 (17.1)	1.60 (17.1)	1.60 (17.1)	1.60 (17.1)
COMPRESSOR (Qty. Per Unit)	Hermetic Recip.	1	1	1	1 (tandem)
AIR FILTERS	Quantity Per Unit (15" X 20" X 1" or 2")	2	2	2	2
	Quantity Per Unit (14" X 25" X 1" or 2")	1	1	1	1
	Total Face Area m ² (ft. ²)	0.59 (6.3)	0.59 (6.3)	0.59 (6.3)	0.59 (6.3)
CHARGE	Refrigerant 407C kg (lbs./oz)	2.7 (6/0)	3.0 (6/10)	2.8 (6/12)	4.5/10

1. R-407C units may require a super heat and sub-cooling check at the job site to ensure proper charge and operation.

TABLE 16: ELECTRIC HEAT CORRECTION FACTORS

NOMINAL VOLTAGE	VOLTAGE	kW CAP. MULTIPLIER
380	380	0.627
415	415	0.75

TABLE 17: VOLTAGE LIMITATIONS

POWER SUPPLY	VOLTAGE	
	MIN.	MAX.
380/415-3-50	342	456

TYPICAL POWER WIRING

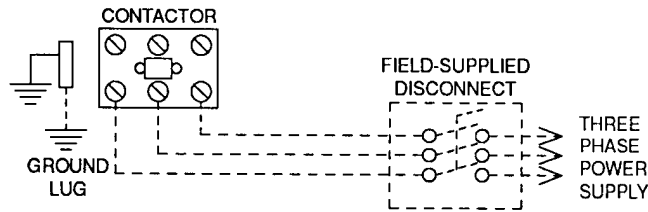

TYPICAL CONTROL WIRING

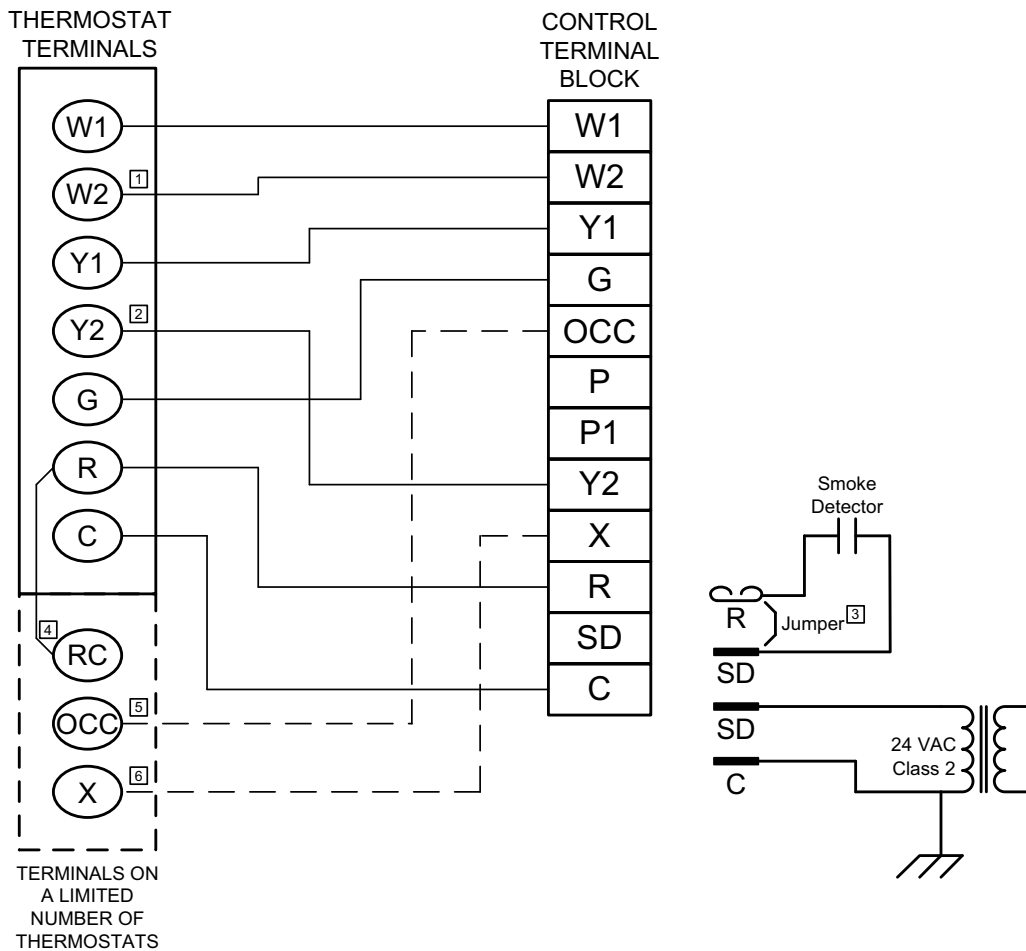

- 1 Second stage heating not required on single stage heating units.
- 2 Second stage cooling not required on single stage cooling units.
- 3 Jumper is required if there is no Smoke Detector circuit.
- 4 Jumper is required for any combination of R, RC, or RH.
- 5 OCC is an output from the thermostat to indicate the Occupied condition.
- 6 X is an input to the thermostat to display Error Status conditions.

FIGURE 2 - TYPICAL FIELD POWER & CONTROL WIRING

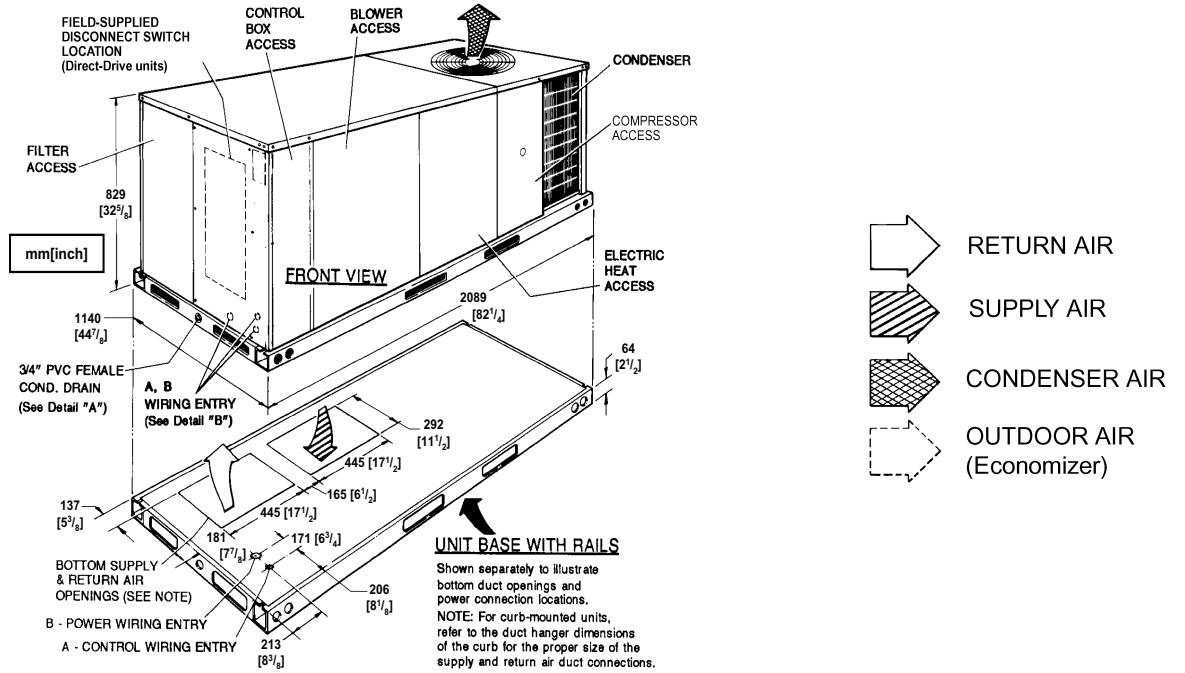

FIGURE 3 - UNIT DIMENSIONS (3 - 6 TON COOLING ONLY/ELECTRIC HEAT) FRONT VIEW

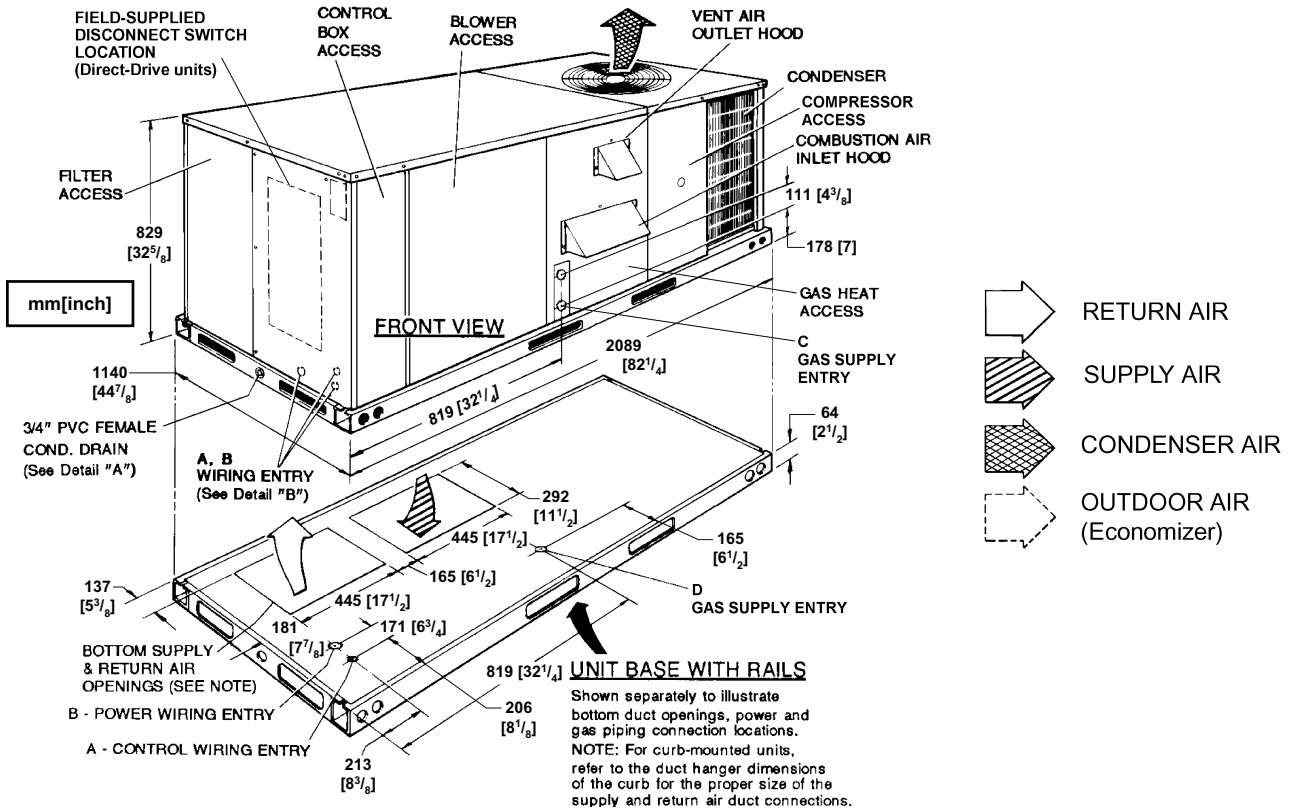

FIGURE 4 - UNIT DIMENSIONS (3 - 6 TON COOLING/GAS HEAT) FRONT VIEW

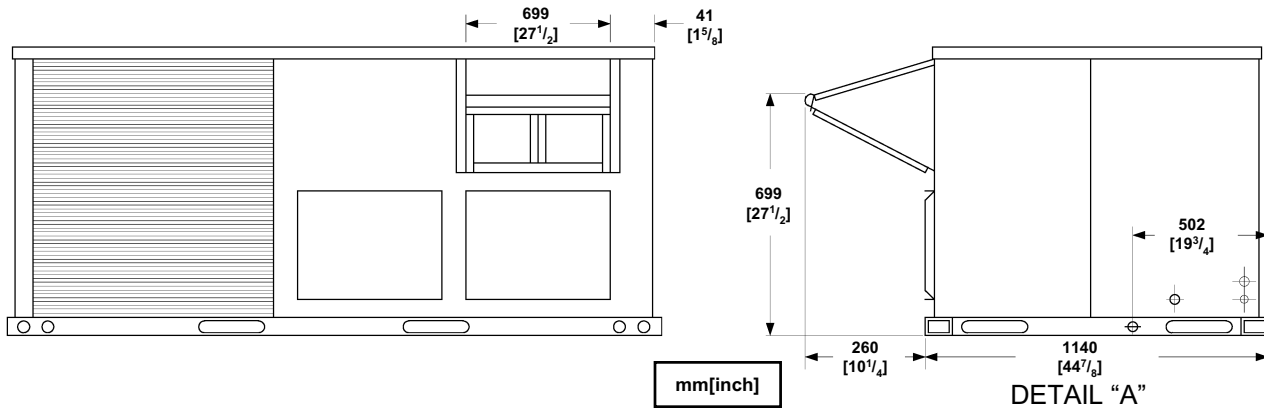

FIGURE 5 - UNIT WITH ECONOMIZER RAINHOOD

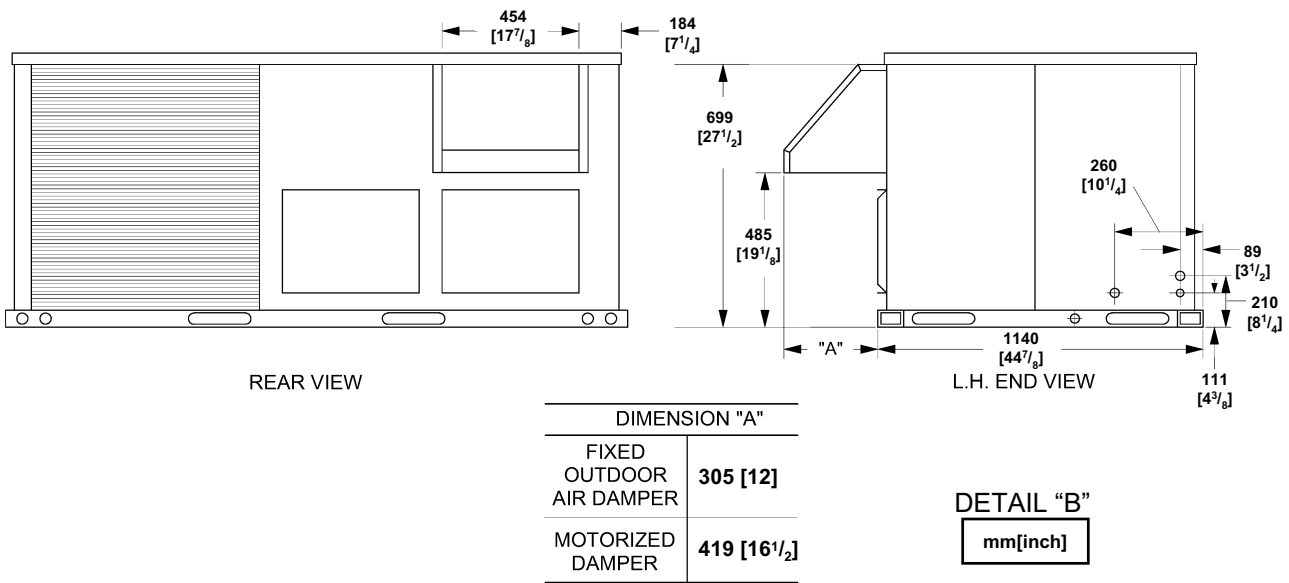

FIGURE 6 - UNIT WITH FIXED OUTDOOR AIR/MOTORIZED DAMPER RAINHOOD

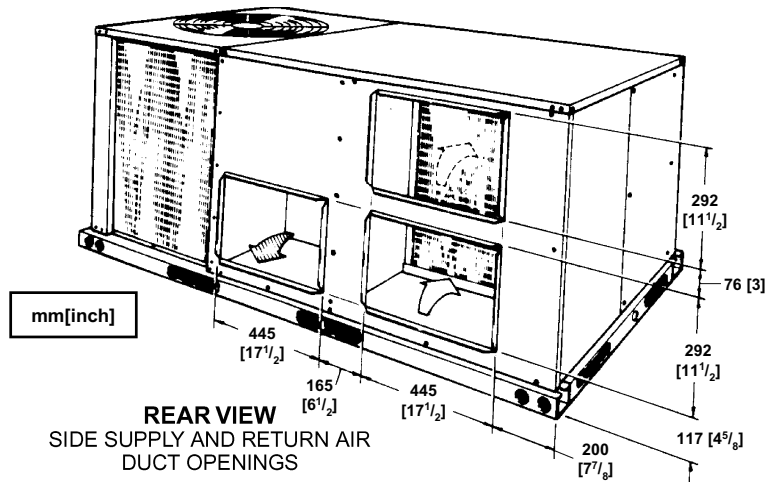

FIGURE 7 - UNIT DIMENSIONS (REAR VIEW)

DUCT COVERS - Units are shipped with all air duct openings covered.

For **side** duct applications;

1. Remove and discard the supply and return air duct covers.
2. Connect ductwork to duct flanges on the rear of the unit.

For **bottom** duct applications;

1. Remove the side supply air duct cover to gain access to the bottom supply air knockout panel.
2. Remove and discard the bottom knockout panel.
3. Replace the side duct cover.
4. With filter section access panel removed from the unit, remove and discard the bottom return air knockout panel.
5. Replace the filter access panel.

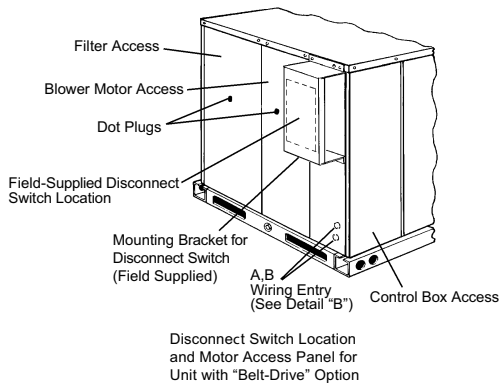

FIGURE 8 - DISCONNECT/BLOWER ACCESS LOCATION

TABLE 19: MINIMUM CLEARANCES

LOCATION	CLEARANCE (mm / In.)
Front	610 / 24.0 (Cooling/Electric Heat) 813 / 32.0 (Gas Heat)
Rear	305 / 12.0 (Less Economizer) 914 / 36.0 (With Economizer or Fixed Air/Motorized Damper)
Left Side (Filter Access)	610 / 24.0 (Less Economizer) 914 / 36.0 (With Economizer)
Right Side (Cond. Coil)	610 / 24.0
Below Unit¹	0
Above Unit²	1829 / 72.0 (For Condenser Air Discharge)

1. Units may be installed on combustible floors made from wood or class A, B, or C roof covering material.
2. Units must be installed outdoors. Overhanging structures or shrubs should not obstruct condenser air discharge outlet.

TABLE 18: UTILITIES ENTRY

HOLE	OPENING SIZE (DIA.) (mm/in)	USED FOR
A	22 / 0.88 KO ¹	Control Wiring ²
		Side
B	51 / 2.0 KO ¹	Power Wiring
		Side
C	41 / 1.63 KO	Gas Piping (Front)
D	38 / 1.5 KO	Gas Piping (Bottom)

1. Opening in the bottom to the unit can be located by the side in the insulation.
2. Do not remove the 2" knockout ring.

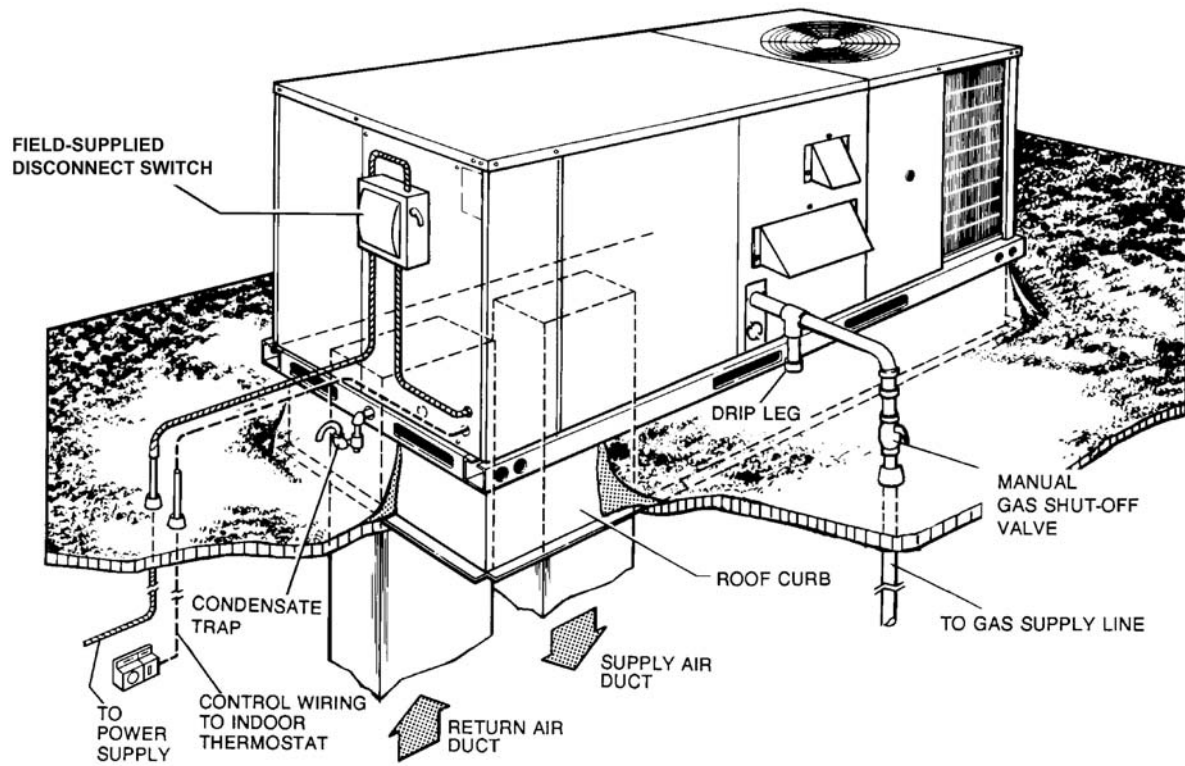
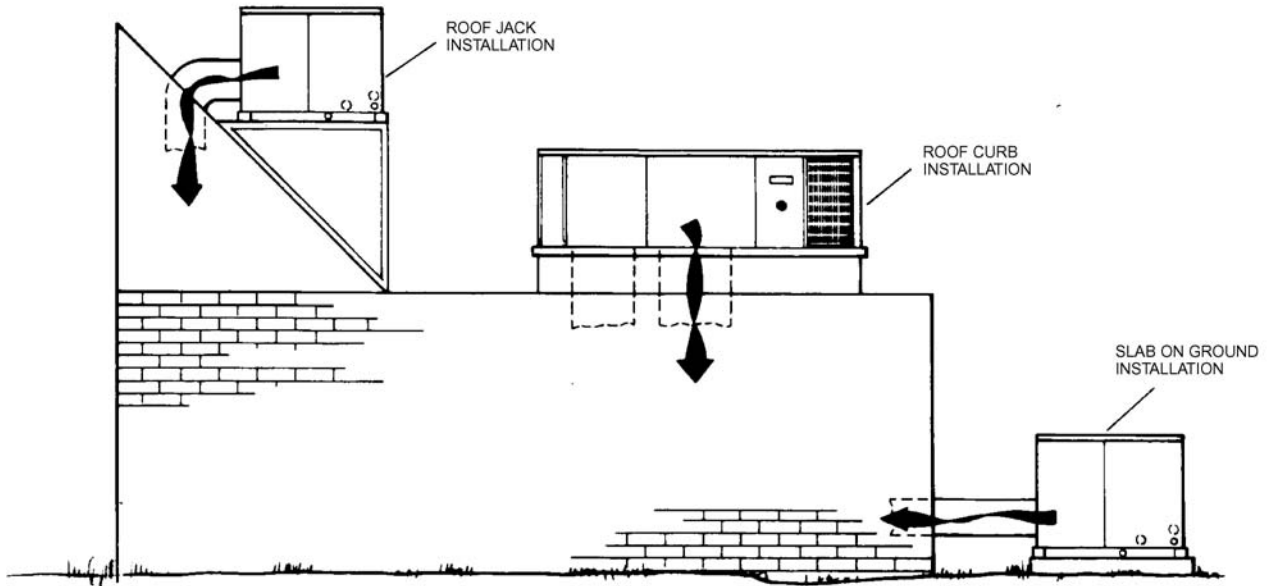

FIGURE 9 - TYPICAL APPLICATIONS

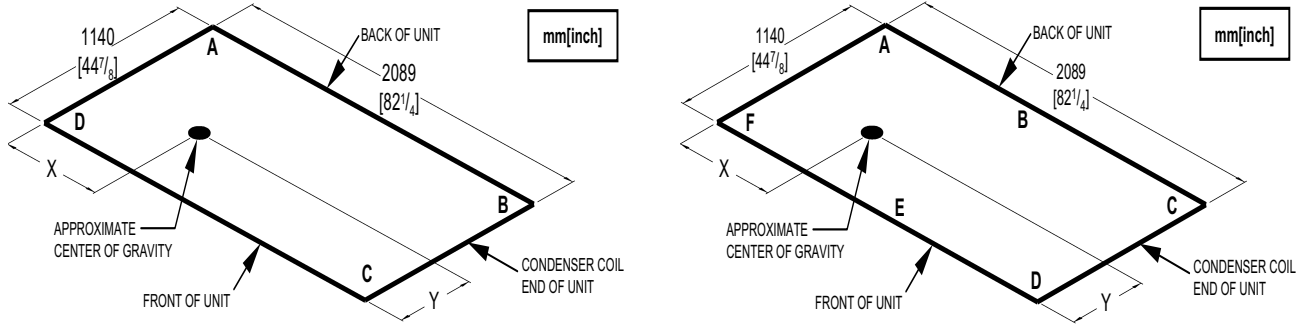

FIGURE 10 - FOUR AND SIX POINT LOADING

TABLE 20: DC 4 POINT LOADS WEIGHT DISTRIBUTION (kg / lbs)

UNIT	TOTAL	A	B	C	D
DC036 Cooling/ Electric	250 / 550	55 / 122	54 / 120	69 / 153	70 / 155
DC036N04	277 / 610	61 / 135	60 / 133	77 / 169	78 / 172
DC048 Cooling/ Electric	268 / 590	59 / 131	58 / 129	74 / 164	76 / 167
DC048N06	295 / 650	65 / 144	64 / 142	82 / 180	83 / 184
DC060 Cooling/ Electric	286 / 630	63 / 140	62 / 137	79 / 175	81 / 178
DC060N08	313 / 690	69 / 153	68 / 150	87 / 191	88 / 195
DC076 Cooling/ Electric	313 / 690	71 / 157	82 / 181	85 / 188	74 / 164
DC076N08	338 / 745	77 / 170	89 / 195	92 / 203	80 / 177

TABLE 21: DC 6 POINT LOADS WEIGHT DISTRIBUTION (kg / lbs)

UNIT	TOTAL	A	B	C	D	E	F
DC036 Cooling/ Electric	250 / 550	37 / 81	37 / 82	36 / 80	46 / 101	47 / 103	47 / 104
DC036N04	277 / 610	41 / 91	41 / 89	40 / 88	51 / 112	52 / 114	52 / 115
DC048 Cooling/ Electric	268 / 590	40 / 88	39 / 87	39 / 85	49 / 109	50 / 110	51 / 111
DC048N06	295 / 650	44 / 97	43 / 95	43 / 94	54 / 120	55 / 121	56 / 123
DC060 Cooling/ Electric	286 / 630	42 / 94	42 / 92	41 / 91	53 / 116	53 / 118	54 / 119
DC060N08	313 / 690	46 / 102	46 / 101	45 / 100	58 / 127	58 / 127	59 / 130
DC076 Cooling/ Electric	313 / 690	46 / 102	51 / 112	56 / 124	58 / 128	53 / 117	48 / 107
DC076N08	338 / 745	50 / 111	55 / 121	60 / 133	63 / 139	57 / 126	52 / 115

TABLE 22: CENTER OF GRAVITY

DIMENSION	3 - 5 TON (mm / in)	6 TON (mm / in)
X	1035 / 40-3/4	1118 / 44
Y	502 / 19-3/4	559 / 22

TABLE 23: OPERATING WEIGHTS (kg / lbs.)

MODEL SIZE		3 TON	4 TON	5 TON	6 TON	
BASIC UNIT	DC (Cooling Only)	250 / 550	268 / 590	286 / 630	313 / 690	
	DC (Gas/Electric)	N04	277 / 610	-	-	-
		N06	-	295 / 650	-	-
		N08	-	-	313 / 690	338 / 745
OPTIONS	Economizer	23 / 50				
	Motorized Damper	12 / 26				
	Electric Heater	7 kW	8 / 18			
		10 - 15 kW	10 / 23			
20 - 30 kW		13 / 28				
ACCY.	Roof Curb	42 / 92				
	Barometric Relief / Fixed Air Damper	5 / 10				
	Belt-Drive Blower	2.3 / 5				

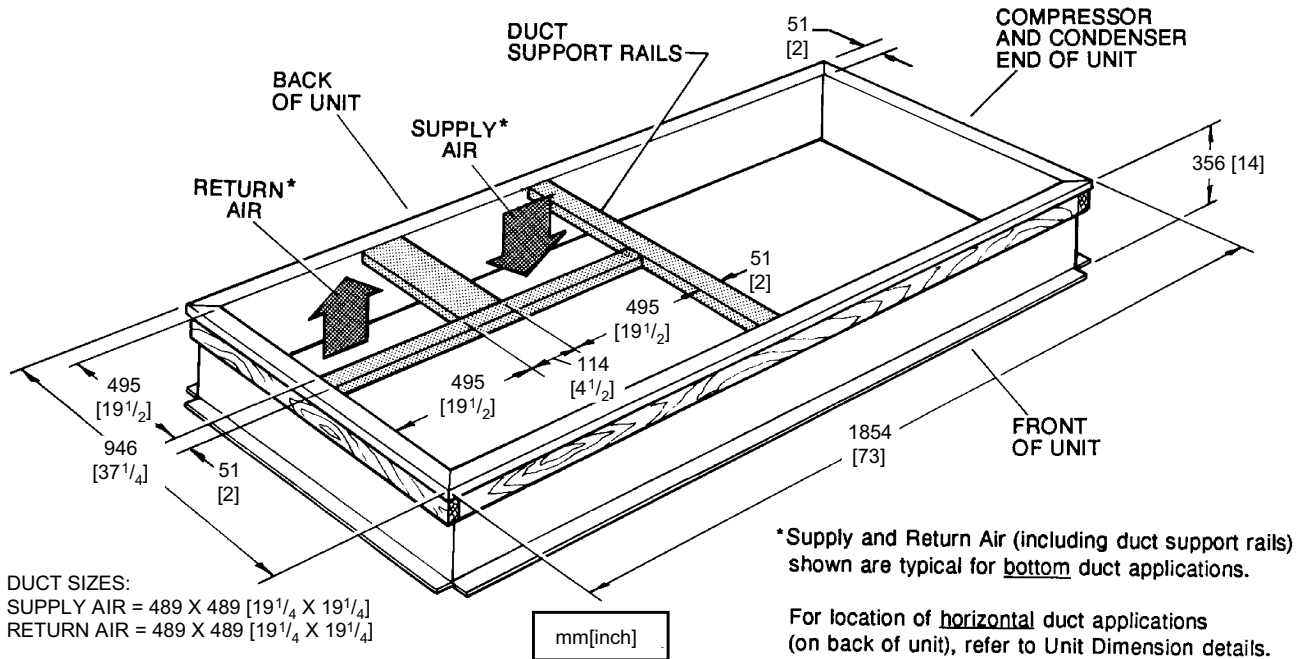

FIGURE 11 - ROOF CURB DIMENSIONS

